

## [A Practical Guide to 'Free Energy' Devices](#)

Part PatD2: Last updated: 28th January 2006

Author: Patrick J. Kelly

Please note that this is a re-worded extract from Edwin Gray's Patent 3,890,548. It describes his high voltage motor and the circuitry used to drive it. This motor was shown to have 80 horsepower of excess energy.

**United States Patent 3,890,548 June 17, 1975 Inventor: Edwin V. Gray snr.**



### PULSED CAPACITOR DISCHARGE ELECTRIC ENGINE

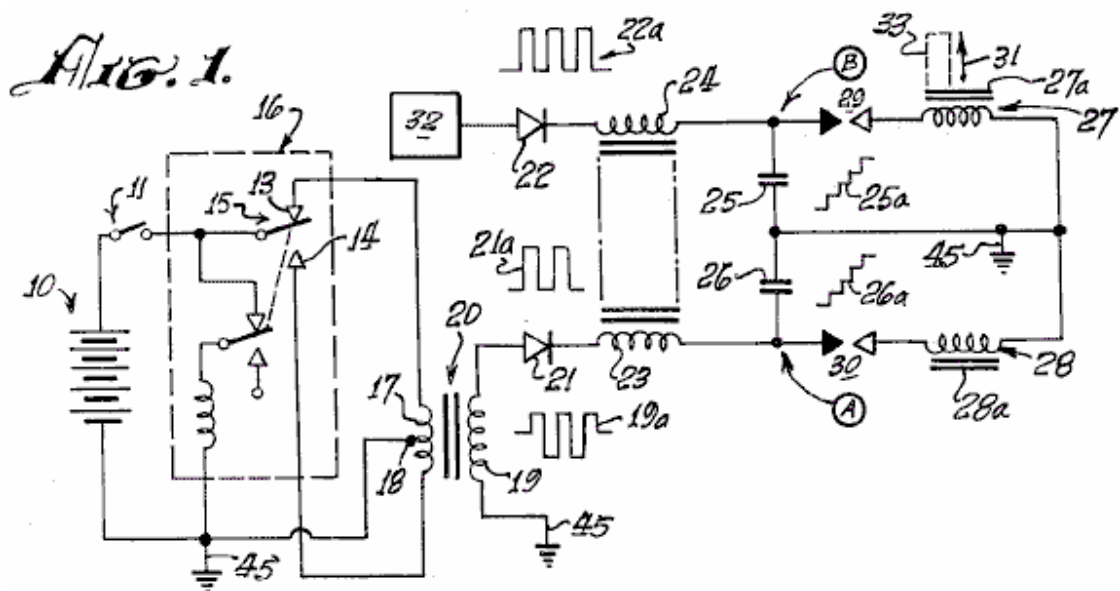
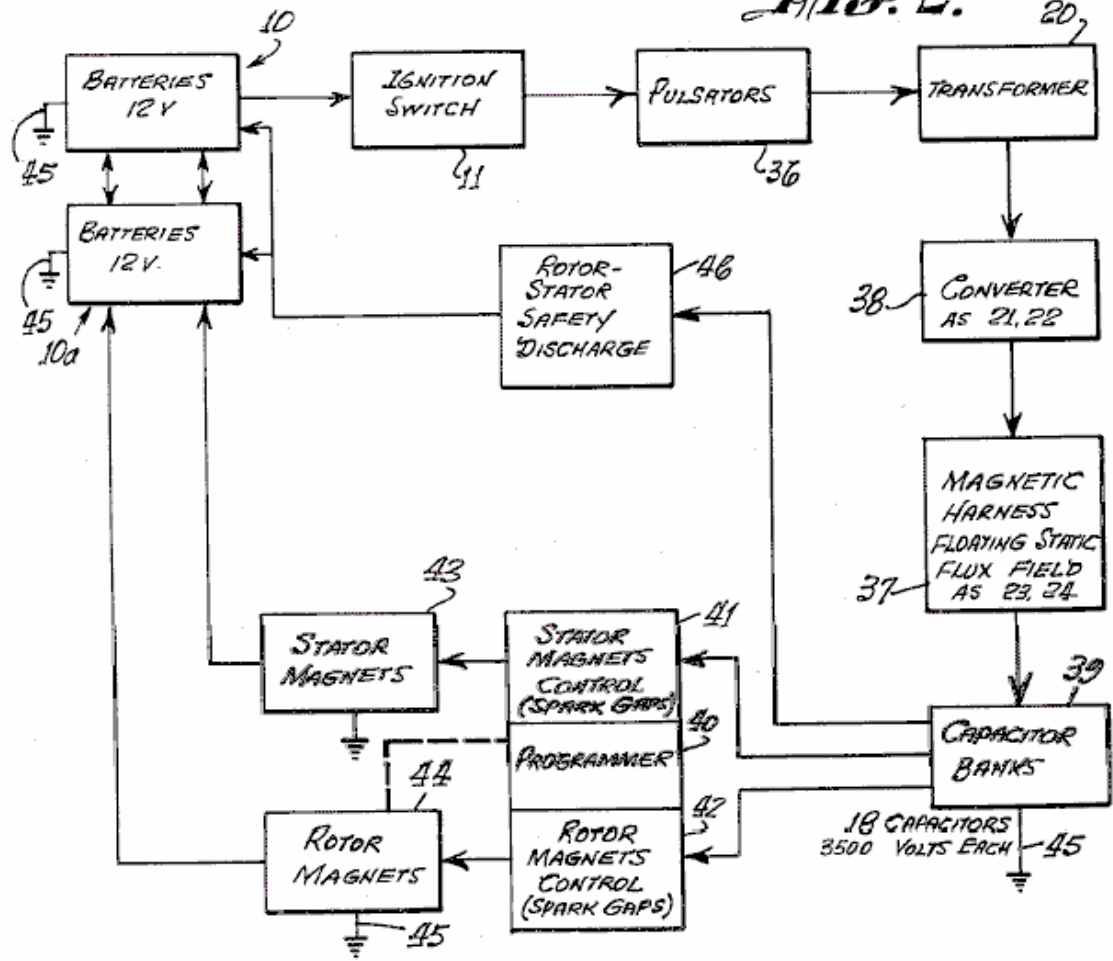
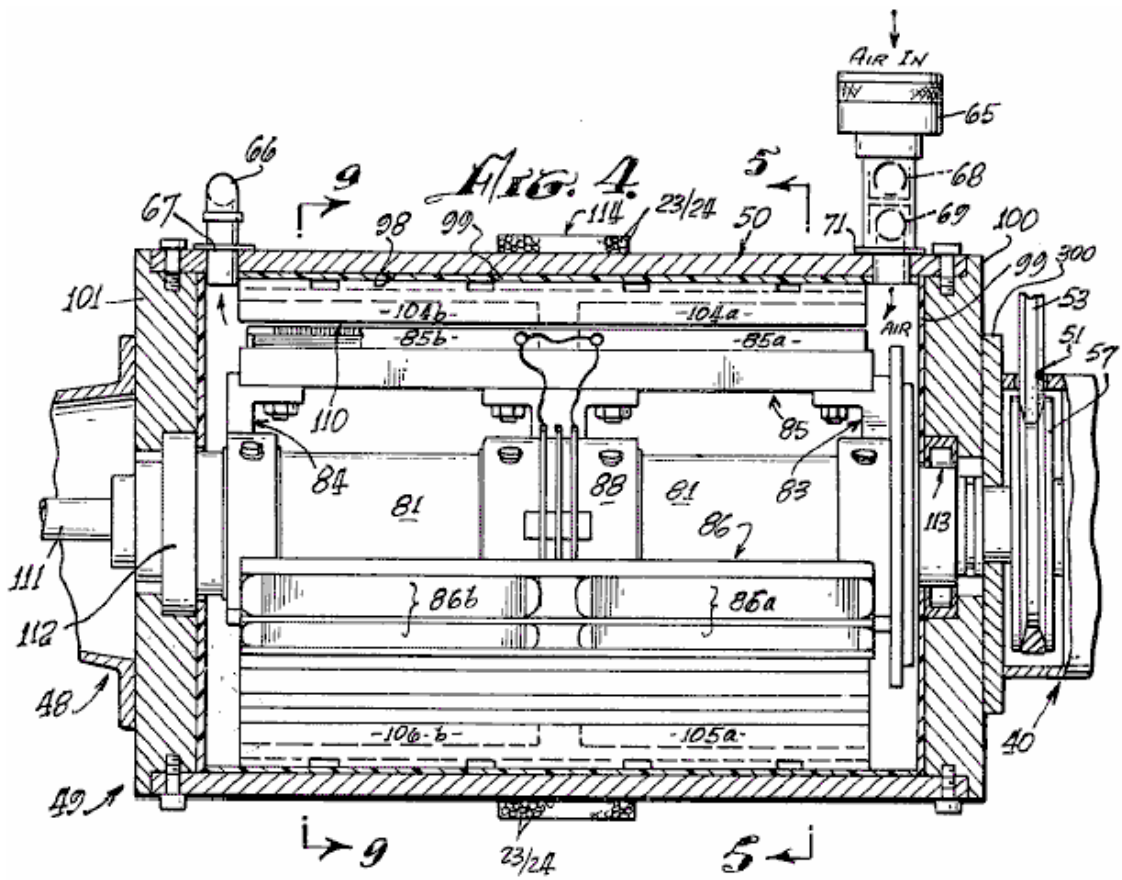
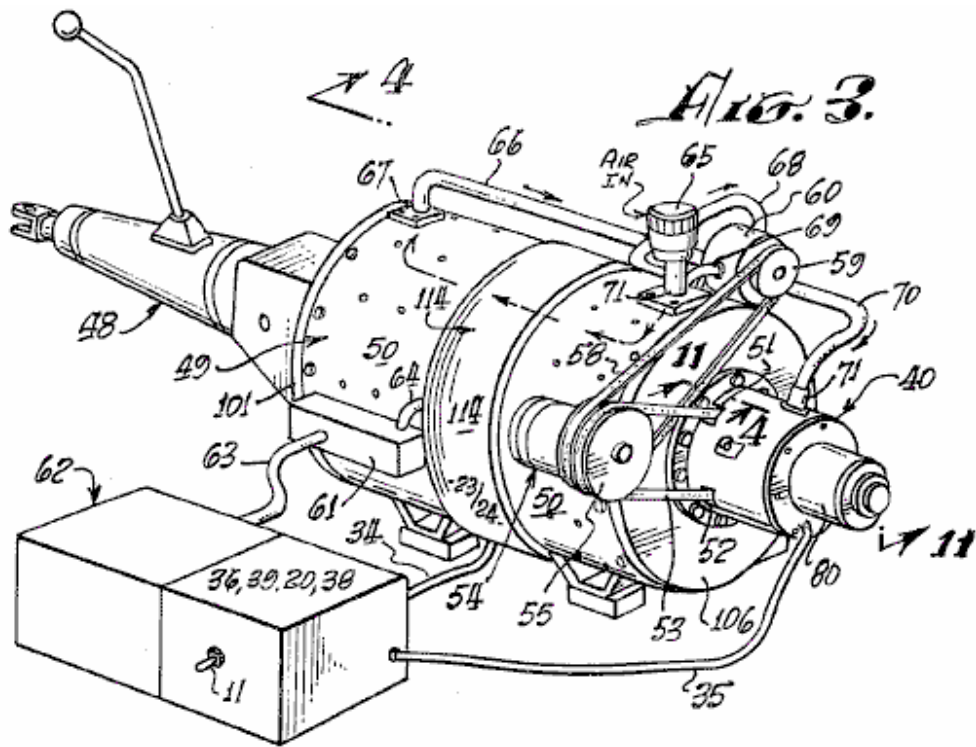
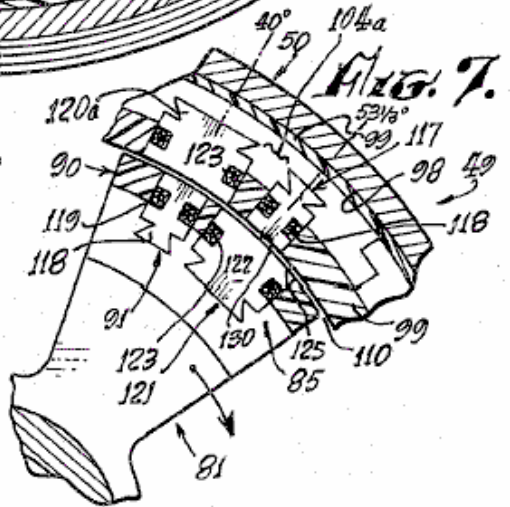
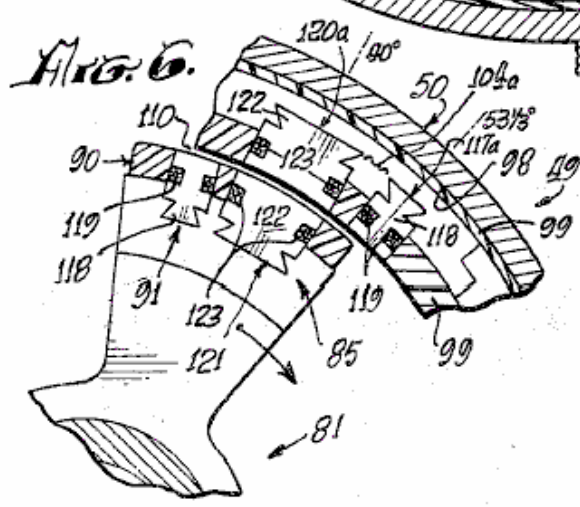
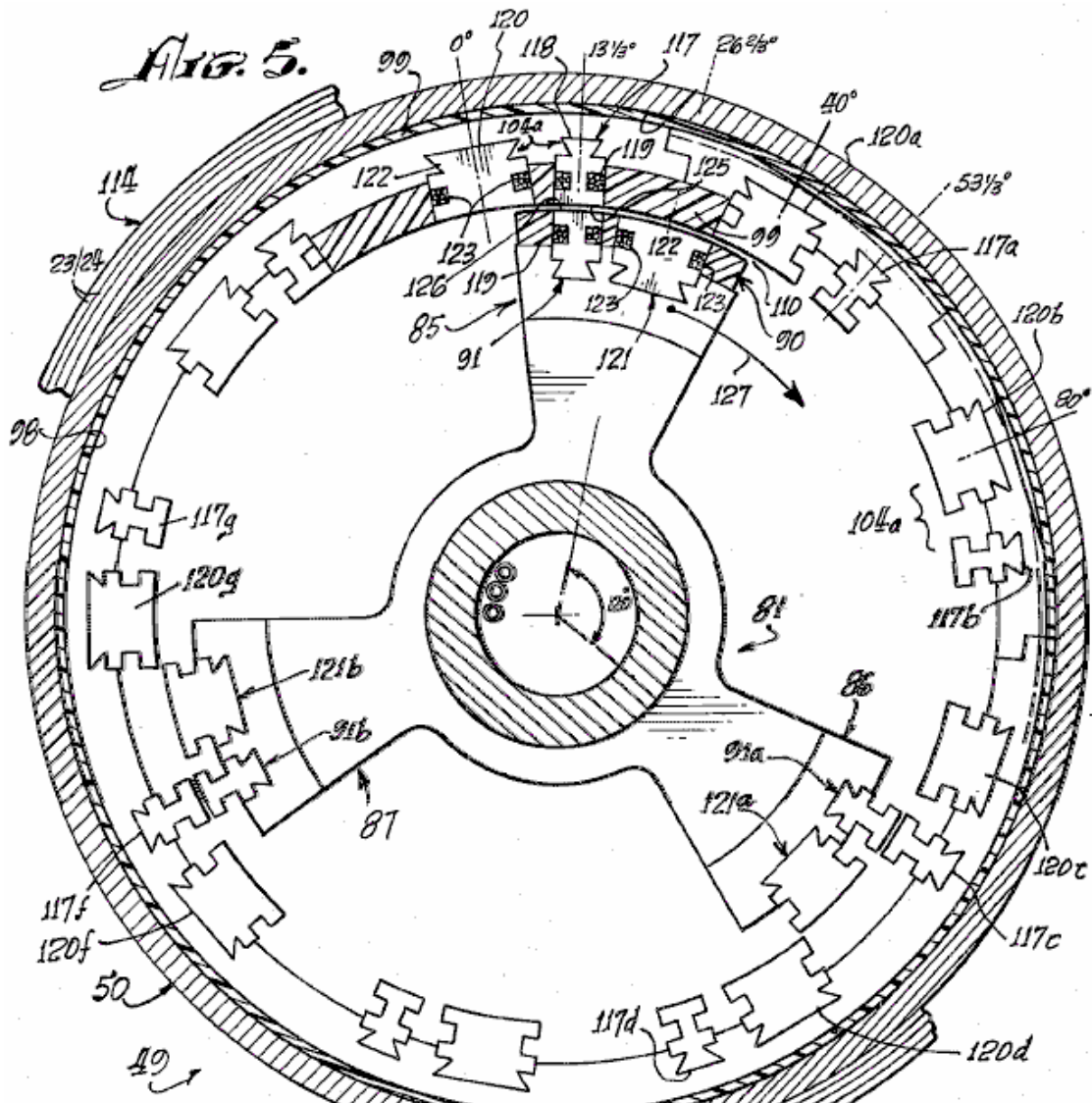

Fig. 2.







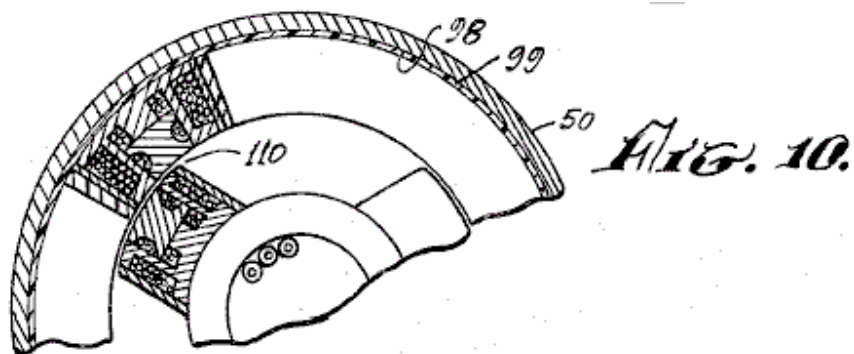
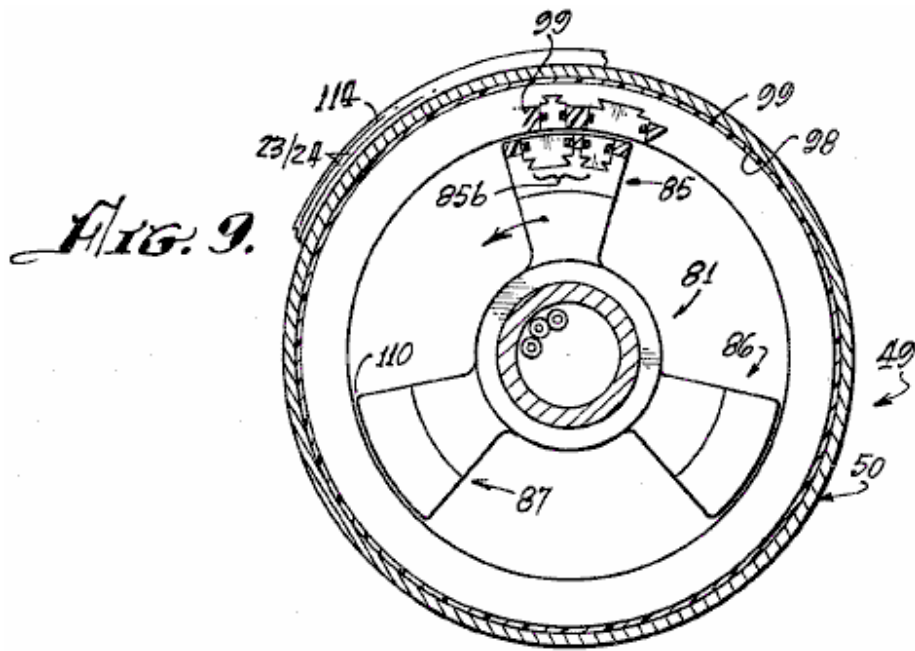
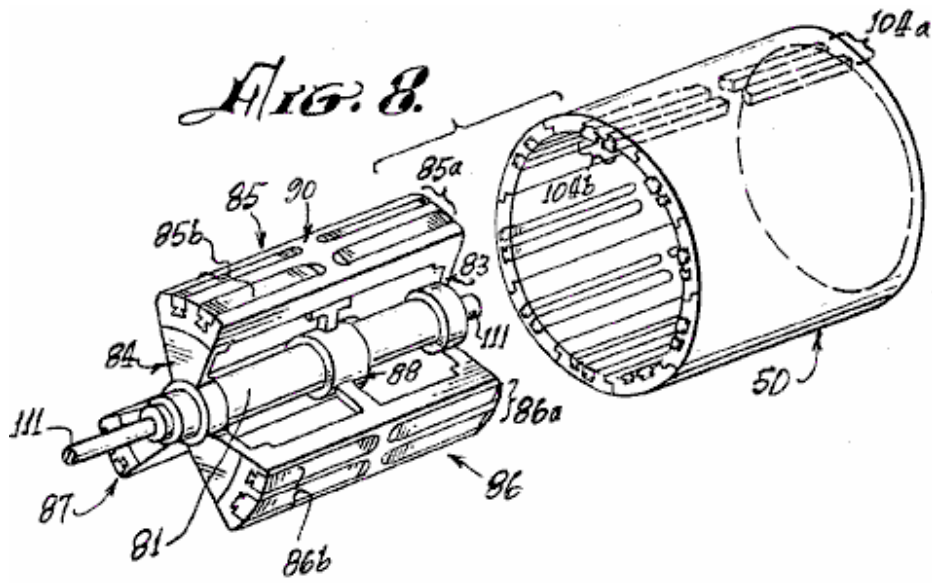
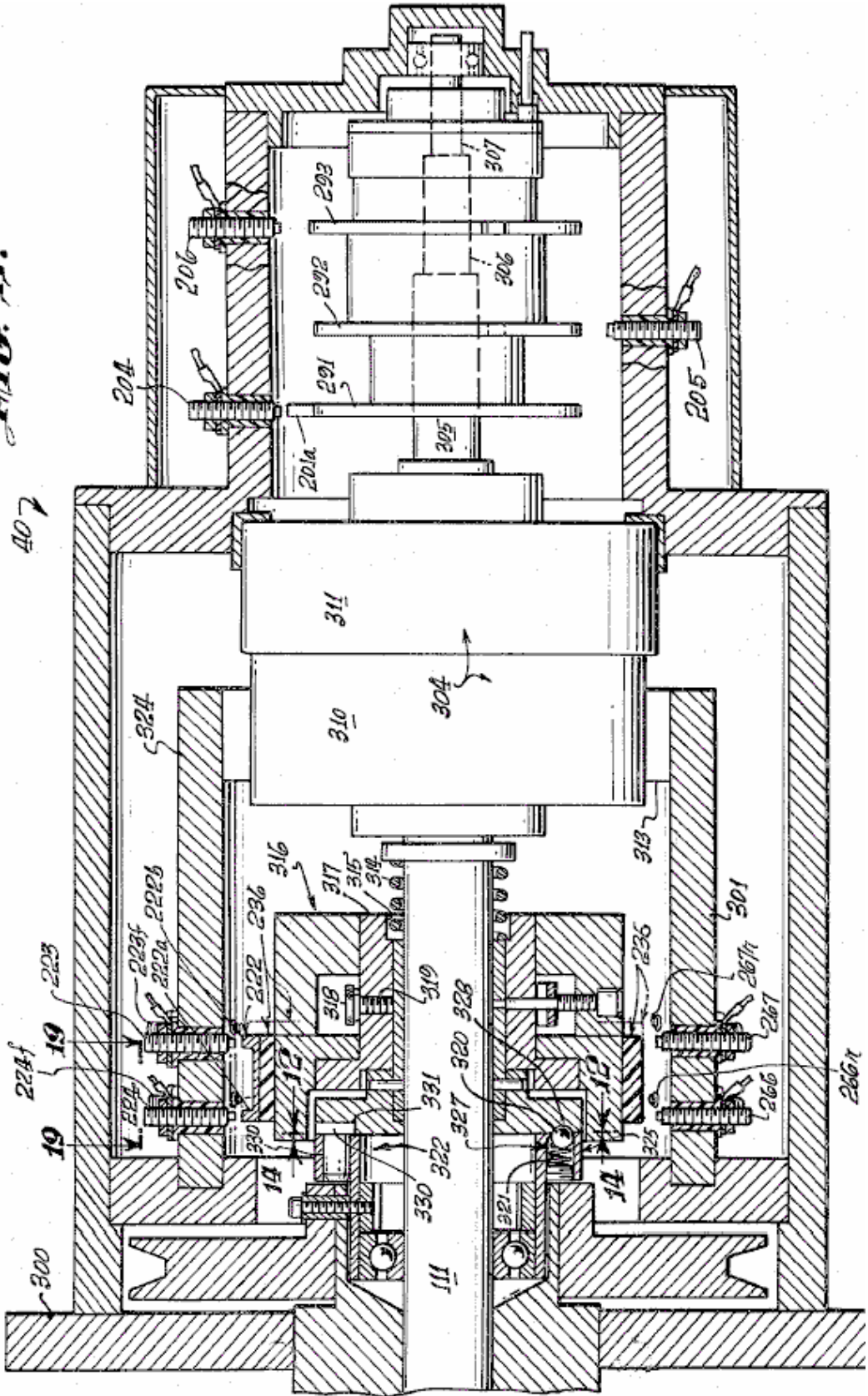



FIG. 11.



407

224f 19 223

300

204

206

201a

205

205

311

310

304

324

223f

222a

222b

222c

222d

222e

222f

222g

316

317

315

318

319

318

330

331

332

327

320

328

313

236

267a

267

266

267b

301

266

267c

267d

267e

267f

266n

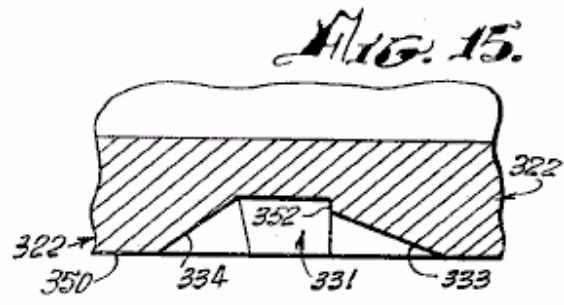
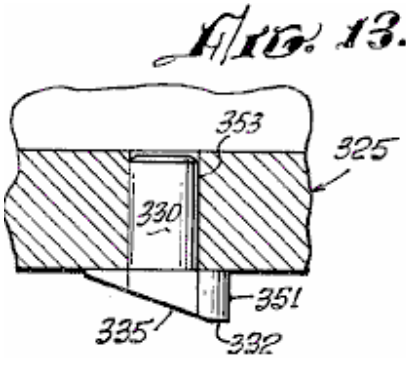
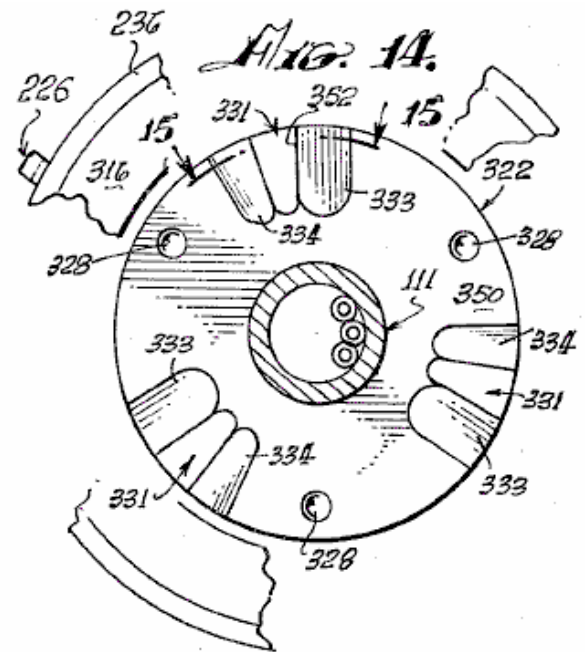
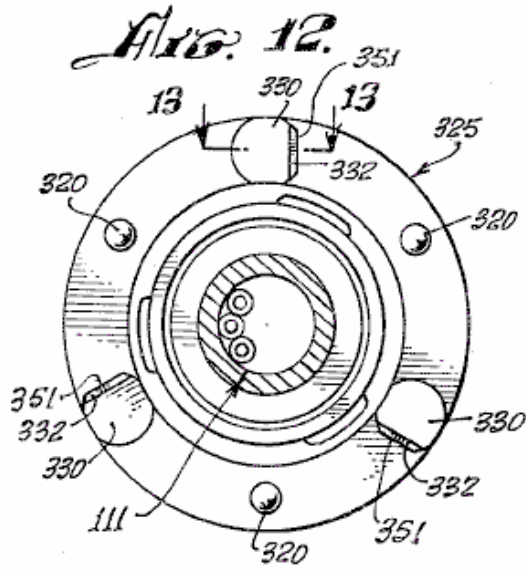

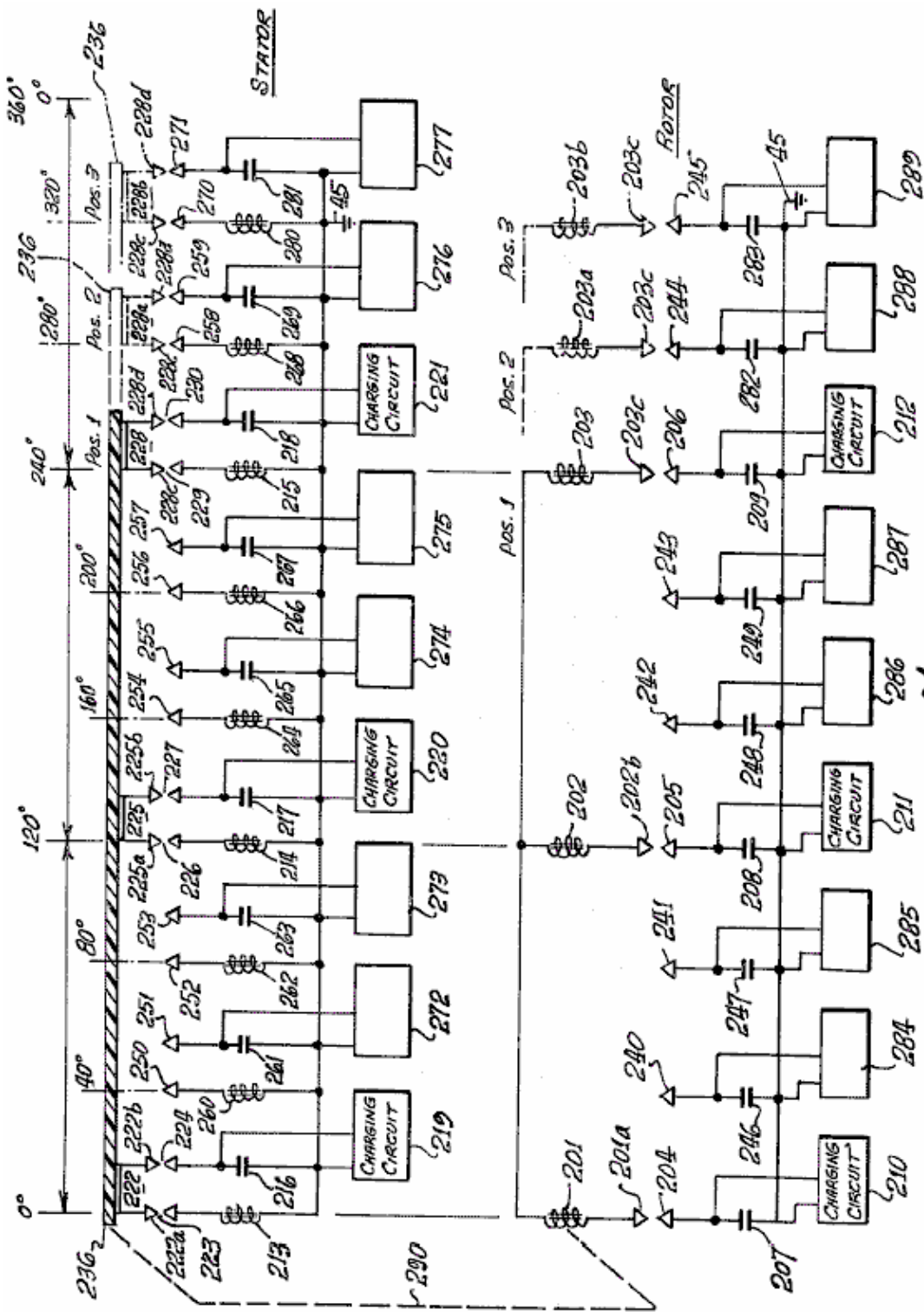

FIG. 18.



## **SUMMARY OF THE INVENTION:**

This invention relates to electric motors or engines, and more particularly to a new electric machine including electromagnetic poles in a stator configuration and electromagnetic poles in a rotor configuration, wherein in one form thereof, the rotor is rotatable within the stator configuration and where both are energised by capacitor discharges through rotor and stator electromagnets at the instant of the alignment of a rotor electromagnet with a stator electromagnet. The rotor electromagnet is repelled from the stator electromagnet by the discharge of the capacitor through the coils of both the rotor and stator electromagnets at the same instant.

In an exemplary rotary engine according to this invention, rotor electromagnets may be disposed 120 degrees apart on a central shaft and major stator electromagnets may be disposed 40 degrees apart in the motor housing about the stator periphery. Other combinations of rotor elements and stator elements may be utilised to increase torque or rate of rotation.

In another form, a second electromagnet is positioned to one side of each of the major stator electromagnets on a centreline 13.5 degrees from the centreline of the stator magnet, and these are excited in a predetermined pattern or sequence. Similarly, to one side of each rotor electromagnet, is a second electromagnet spaced on a 13.5 degree centreline from the major rotor electromagnet. Electromagnets in both the rotor and stator assemblies are identical, the individual electromagnets of each being aligned axially and the coils of each being wired so that each rotor electromagnetic pole will have the same magnetic polarity as the electromagnet in the stator with which it is aligned and which it is confronting at the time of discharge of the capacitor.

Charging of the discharge capacitor or capacitors is accomplished by an electrical switching circuit wherein electrical energy from a battery or other source of d-c potential is derived through rectification by diodes.

The capacitor charging circuit comprises a pair of high frequency switchers which feed respective automotive-type ignition coils employed as step-up transformers. The "secondary" of each of the ignition coils provides a high voltage square wave to a half-wave rectifier to generate a high voltage output pulse of d-c energy with each switching alternation of the high frequency switcher. Only one polarity is used so that a unidirectional pulse is applied to the capacitor bank being charged.

Successive unidirectional pulses are accumulated on the capacitor or capacitor bank until discharged. Discharge of the bank of capacitors occurs across a spark gap by arc-over. The gap spacing determines the voltage at which discharge or arc-over occurs. An array of gaps is created by fixed elements in the engine housing and moving elements positioned on the rotor shaft. At the instant when the moving gap elements are positioned opposite fixed elements during the rotor rotation, a discharge occurs through the coils of the aligned rotor and stator electromagnets to produce the repulsion action between the stator and rotor electromagnet cores.

A plurality of fixed gap elements are arrayed in a motor housing to correspond to the locations of the stator electromagnets in the housing. The rotor gap elements correspond to the positions of the rotor electromagnets on the rotor so that at the instant of correct alignment of the gaps, the capacitors are discharged to produce the necessary current through the stator and rotor coils to cause the electromagnets to repel one another.

The charging circuits are arranged in pairs, and are such that the discharge occurs through both rotor and stator windings of the electromagnets, which are opposite one another when the spark gap elements are aligned and arc-over.

The speed of the rotor can be changed by means of a clutch mechanism associated with the rotor. The clutch shifts the position of the rotor gap elements so that the discharge will energise the stator coils in a manner to advance or retard the time of discharge with respect to the normal rotor/stator alignment positions. The discharge through the rotor and stator then occurs when the rotor has passed the stator by 6.66 degrees for speed advance.

By causing the discharge to occur when the rotor position is approaching the stator, the repulsion pulse occurs 6.66 degrees before the alignment position of the rotor and stator electromagnets, thus reducing the engine speed.

The clutch mechanism for aligning capacitor discharge gaps for discharge is described as a control head. It may be likened to a firing control mechanism in an internal combustion engine in that it "fires" the electromagnets and provides a return of any discharge overshoot potential back to the battery or other energy source.

The action of the control head is extremely fast. From the foregoing description, it can be anticipated that an increase in speed or a decrease in speed of rotation can occur within the period in which the rotor electromagnet moves between any pair of adjacent electromagnets in the stator assembly. These are 40 degrees apart so speed changes can be effected in a maximum of one-ninth of a revolution.

The rotor speed-changing action of the control head and its structure are believed to be further novel features of the invention, in that they maintain normal 120 degree firing positions during uniform speed of rotation conditions, but shift to 6.66 degree longer or shorter intervals for speed change by the novel shift mechanism in the rotor clutch assembly.

Accordingly, the preferred embodiment of this invention is an electric rotary engine wherein motor torque is developed by discharge of high potential from a bank of capacitors, through stator and rotor electromagnet coils when the electromagnets are in alignment. The capacitors are charged from batteries by a switching mechanism, and are discharged across spark gaps set to achieve the discharge of the capacitor charge voltage through the electromagnet coils when the gaps and predetermined rotor and stator electromagnet pairs are in alignment.

Exemplary embodiments of the invention are herein illustrated and described. These exemplary illustrations and description should not be construed as limiting the invention to the embodiments shown, because those skilled in the arts appertaining to the invention may conceive of other embodiments in the light of the description within the ambit of the appended claims.

#### **BRIEF DESCRIPTION OF THE DRAWINGS:**

**Fig.1** is an explanatory schematic diagram of a capacitor charging and discharging circuit utilised in the present invention.

**Fig.2** is a block diagram of an exemplary engine system according to the invention.

**Fig.3** is a perspective view of a typical engine system according to the invention, coupled to an automotive transmission.

**Fig.4** is an axial sectional view taken at line 4---4 in Fig.3

**Fig.5** is a sectional view taken at line 5---5 in Fig.4

**Fig.6** and **Fig.7** are fragmentary sectional views, corresponding to a portion of Fig.5, illustrating successive advanced positions of the engine rotor therein.

**Fig.8** is an exploded perspective view of the rotor and stator of the engine of Fig.3 and Fig.4

**Fig.9** is a cross-sectional view taken at line 9---9 of Fig.4

**Fig.10** is a partial sectional view, similar to the view of Fig.9, illustrating a different configuration of electromagnets in another engine embodiment of the invention.

**Fig.11** is a sectional view taken at line 11---11 in Fig.3, illustrating the control head or novel speed change controlling system of the engine.

**Fig.12** is a sectional view, taken at line 12---12 in Fig.11, showing a clutch plate utilised in the speed change control system of Fig.11

**Fig.13** is a fragmentary view, taken at line 13---13 in Fig.12

**Fig.14** is a sectional view, taken at line 14---14 in Fig.11, showing a clutch plate which co-operates with the clutch plate of Fig.12

**Fig.15** is a fragmentary sectional view taken at line 15---15 of Fig.13

**Fig.16** is a perspective view of electromagnets utilised in the present invention.

**Fig.17** is a schematic diagram showing co-operating mechanical and electrical features of the programmer portion of the invention.

**Fig.18** is an electrical schematic diagram of an engine according to the invention, showing the electrical relationships of the electromagnetic components embodying a new principle of the invention, and

**Fig.19** is a developed view, taken at line 19---19 of Fig.11, showing the locations of displaced spark gap elements of the speed changing mechanism of an engine according to the invention.

#### **DESCRIPTION OF THE PREFERRED EMBODIMENT:**

As mentioned earlier, the basic principle of operation of the engine of the invention, is the discharge of a capacitor across a spark gap and through an inductor. When a pair of inductors is used, and the respective magnetic cores thereof are arranged opposite one another and arranged in opposing magnetic polarity, the discharge through them causes the cores to repel each other with considerable force.

Referring to the electrical schematic diagram of **Fig.1**, a battery **10** energises a pulse-producing vibrator mechanism **16**, which may be of the magnetic type, incorporating an armature **15** moving between contacts **13** and **14**, or of the transistor type (not shown) with which a high frequency bipolar pulsed output is produced in primary **17** of transformer **20**. The pulse amplitude is stepped up in secondary **19** of transformer **20**. Wave form **19a** represents the bi-directional or bipolar pulsed output. A diode rectifier **21** produces a unidirectional pulse train, as indicated at **21a**, to charge capacitor **26**. Successive unidirectional pulses of wave **21a** charge capacitor **26** to high level, as indicated at **26a**, until the voltage at point **A** rises high enough to cause a spark across the spark gap **30**. Capacitor **26** discharges via the spark gap, through the electromagnet coil **28**. A current pulse is produced which magnetises core **28a**. Simultaneously, another substantially identical charging system **32** produces a discharge through inductor **27** across spark gap **29**, to magnetise core **27a**. Cores **27a** and **28a** are wound with coils **27** and **28** respectively, so that their magnetic polarities are the same. As the cores **27a** and **28a** confront one another, they tend to fly apart when the discharge occurs through coils **27** and **28** because of

repulsion of identical magnetic poles, as indicated by arrow **31**. If core **28a** is fixed or stationary, and core **27a** is moveable, then core **27a** may have tools **33** attached to it to perform work when the capacitor discharges.

Referring to **Fig.1** and **Fig.2**, a d-c electrical source or battery **10**, energises pulsators **36** (including at least two vibrators **16** as previously described) when switch 11 between the battery **10** and pulsator **36** is closed, to apply relatively high frequency pulses to the primaries of transformers **20**. The secondaries of transformers **20** are step-up windings which apply bipolar pulses, such as pulses **19a** (Fig.1) to the diodes in converter **38**. The rectified unidirectional pulsating output of each of the diodes in converter **38** is passed through delay coils **23** and **24**, thus forming a harness **37**, wound about the case of the engine, as herein after described, which is believed to provide a static floating flux field. The outputs from delay lines **37**, drive respective capacitors in banks **39**, to charge the capacitors therein, to a relatively high charge potential. A programmer and rotor and stator magnet control array **40, 41, 42**, is formed by spark gaps positioned, as hereinafter described, so that at predetermined positions of the rotor during rotation of the engine, as hereinafter described, selected capacitors of the capacitor banks **39** will discharge across the spark gaps through the rotor and stator electromagnets **43** and **44**. The converters **38**, programmer **40**, and controls **41** and **42**, form a series circuit path across the secondaries of transformers **20** to the ground, or point of reference potential, **45**. The capacitor banks **39** are discharged across the spark gaps of programmer **40** (the rotor and stator magnet controls **41** and **42**). The discharge occurs through the coils of stator and rotor electromagnets **43** and **44** to ground **45**. Stator and rotor electromagnets are similar to those shown at **27, 27a, 28** and **28a** in **Fig.1**.

The discharge through the coils of stator and rotor electromagnets **43** and **44** is accompanied by a discharge overshoot or return pulse, which is applied to a secondary battery **10a** to store this excess energy. The overshoot pulse returns to battery **10a** because, after discharge, the only path open to it is that to the battery **10a**, since the gaps in **40, 41** and **42** have broken down, because the capacitors in banks **39** are discharged and have not yet recovered the high voltage charge from the high frequency pulsers **36** and the converter rectifier units **38**.

In the event of a misfire in the programmer control circuits **40, 41** and **42**, the capacitors are discharged through a rotor safety discharge circuit **46** and returned to batteries **10-10a**, adding to their capacity. The circuit **46** is connected between the capacitor banks **39** and batteries **10, 10a**.

Referring to **Fig.3**, a motor or engine **49** according to the present invention is shown connected with an automotive transmission **48**. The transmission **48**, represents one of many forms of loads to which the engine may be applied. A motor housing **50**, encases the operating mechanism hereinafter described. The programmer **40** is axially mounted at one end of the housing. Through apertures **51** and **52**, a belt **53** couples to a pulley **57** (not shown in this view) and to an alternator **54** attached to housing **50**. A pulley **55** on the alternator, has two grooves, one for belt **53** to the drive pulley **58** on the shaft (not shown) of the engine **49**, and the other for a belt **58** coupled to a pulley **59** on a pump **60** attached to housing **50**. A terminal box **61** on the housing, interconnects between the battery assembly **62** and motor **49** via cables **63** and **64**.

An intake **65** for air, is coupled to pump **60** via piping **68** and **69** and from pump **60** via tubing or piping **66** and **70** to the interior of housing **50** via coupling flanges **67** and **71**. The air flow tends to cool the engine and the air may preferably be maintained at a constant temperature and humidity so that a constant spark gap discharge condition is maintained. A clutch mechanism **80** is provided on programmer **40**.

Referring to **Fig.4, Fig.5** and **Fig.9**, rotor **81** has spider assemblies **83** and **84** with three electromagnet coil assembly sets mounted thereon, two of which are shown in **Fig.4**, on **85, 85a** and **85b** and on **86** at **86a** and **86b**. One of the third electromagnet coil assemblies, designated **87a**, is shown in **Fig.5**, viewed from the shaft end. As more clearly shown in the

perspective view of **Fig.8**, a third spider assembly **88** provides added rigidity and a central support for the rotor mechanism on shaft **81**.

The electromagnet sets **85a, 85b, 86a, 86b, 87a** and **87b**, disposed on rotor **81** and spiders **83, 84** and **88**, each comprise pairs of front units **85a, 86a** and **87a** and pairs of rear units **85b, 86b** and **87b**. Each pair consists of a major electromagnet and a minor electromagnet, as hereinafter described, which are imbedded in an insulating material **90**, which insulates the electromagnet coil assemblies from one another and secures the electromagnets rigidly in place on the spider/rotor cage **81, 83, 84** and **88**.

The interior wall **98**, of housing **50**, is coated with an electrically insulating material **99** in which are imbedded electromagnet coils, as hereinafter described, and the interiors of end plates **100** and **101** of the housing **50**. On the insulating surface **98** of housing **50** is mounted a series of stator electromagnet pairs **104a**, identical with electromagnet pairs **85a, 86a, 87a**, etc. Electromagnet pairs such as **104a** or **105a** are disposed every **40** degrees about the interior of housing **50** to form a stator which co-operates with the rotor **81-88**. An air gap **110** of very close tolerance is defined between the rotor and stator electromagnets and air from pump **65** flows through this gap.

As shown in **Fig.8**, the electromagnet assemblies, such as **85** through **87**, of the rotor and magnet assemblies, such as **104a** in the stator, are so embedded in their respective insulating plastic carriers (rotor and stator) that they are smoothly rounded in a concave contour on the rotor to permit smooth and continuous rotation of rotor **81** in stator housing **50**. The air gap **110** is uniform at all positions of any rotor element within the stator assembly, as is clearly shown in **Fig.16**.

The rotor **81** and spiders **83, 84** and **88** are rigidly mounted on shaft **111** journaled in bearing assemblies **112** and **113** which are of conventional type, for easy rotation of the rotor shaft **111** within housing **50**.

Around the central outer surface of housing **50**, are wound a number of turns of wire **23** and **24** to provide a static flux coil **114** which is a delay line, as previously described. **Figs. 5, 6, 7** and **9** are cross-sectional views of the rotor assembly **81-88**, arranged to show the positioning and alignment of the rotor and stator electromagnet coil assemblies at successive stages of the rotation of the rotor **81-88** through a portion of a cycle of operation thereof. For example, in **Fig.5** the rotor assembly **81-88** is shown so positioned that a minor rotor electromagnet assembly **91** is aligned with a minor stator electromagnet assembly **117**.

As shown in further detail in **Fig.16**, minor electromagnet assembly **117** consists of an iron core **118**, grooved so that a coil of wire **119** may be wound around it. Core **118** is the same in stator electromagnet **117** as it is in rotor electromagnet **91**.

As a position 13.33 degrees to the right of rotor electromagnet **91**, as viewed in **Fig.5** and **Fig.16**, there is a second or major rotor electromagnet **121** which has a winding **123** about its core **122**. The electromagnets **91** and **121** are the pair **85a** of **Fig.4** and **Fig.8**.

At a position 13.33 degrees to the left of stator electromagnet **117**, as viewed in **Fig.5**, there is a second or major stator electromagnet **120** whose core **122** is of the same configuration as core **122** of rotor electromagnet **121**. A winding **123** about core **122** of electromagnet **120** is of the same character as winding **123** on electromagnet **121**.

Electromagnet assembly pair **85a** on the rotor is identical in configuration to that of the electromagnet stator assembly pair **104a** except for the position reversal of the elements **117-120** and **91-121** of the respective pairs.



There are nine pairs of electromagnets **120-117 (104a)** located at 40 degree intervals about the interior of housing **50**. The centreline of core **122** of electromagnet **120** is positioned 13.33 degrees to the left of the centreline of the core **118** of electromagnet **117**. Three pairs of electromagnets **85a**, **86a** and **87a** are provided on rotor assembly **81-88** as shown in **Fig.5**.

Other combinations are possible, but the number of electromagnets in the rotor should always be in integral fraction of the number of electromagnets in the stator. As shown in **Fig.8**, for the rotor assembly **85a** and **85b**, there are three of each of the front and back pairs of electromagnetic assemblies. Similarly, as shown in **Fig.4** and **Fig.8**, there are nine front and back pairs of electromagnets in the stator such as **104a** and **104b**.

In order to best understand the operation of the rotor **81-88** rotating within the stator housing **50** of an engine according to this invention, the positions of rotor electromagnets **91** and stator electromagnets **117** are initially exactly in line at the 13.33 degree peripheral starting position marked on the vertical centreline of **Fig.5**. The winding direction of the coils of these magnets is such that a d-c current through the coils **119** will produce a particular identical magnet polarity on each of the juxtaposed surfaces **125** of magnet **117** and **126** of magnet **91 (Fig.5)**. **Fig.16** and **Fig.6** illustrate the next step in the motion wherein the two major electromagnets, **120** in the stator and **121** in the rotor, are in alignment.

When the d-c discharges from the appropriate capacitors in banks **39** occur simultaneously across spark gaps through the coils **119** of electromagnets **117** and **91**, at the instant of their alignment, their cores **118**, will repel one another to cause rotor assembly **81-88** to rotate clockwise in the direction indicated by arrow **127**. The system does not move in the reverse direction because it has been started in the clockwise direction by the alternator motor **54** shown in **Fig.3**, or by some other starter means. If started counterclockwise, the motor will continue to rotate counterclockwise.

As noted earlier, the discharge of any capacitor occurs over a very short interval via its associated spark gap and the resulting magnetic repulsion action imparts motion to the rotor. The discharge event occurs when electromagnets **117** and **91** are in alignment. As shown in **Fig.5**, rotor electromagnet **91a** is aligned with stator electromagnet **117c**, and rotor electromagnet **91b** is aligned with stator electromagnet **117e** at the same time that similar electromagnets **117** and **91** are aligned. A discharge occurs through all six of these electromagnets simultaneously (that is, **117**, **91**, **117c**, **91a**, **117e** and **91b**). A capacitor and a spark gap are required for each coil of each electromagnet. Where, as in the assembly shown in **Fig.8**, front and back pairs are used, both the axial in-line front and back coils are energised simultaneously by the discharge from a single capacitor or from a bank of paralleled capacitors such as **25** and **26 (Fig.1)**. Although **Fig.4** and **Fig.8** indicate the use of front and back electromagnets, it should be evident that only a single electromagnet in any stator position and a corresponding single electromagnet in the rotor position, may be utilised to accomplish the repulsion action of the rotor with respect to the stator. As stated, each electromagnet requires a discharge from a single capacitor or capacitor bank across a spark gap for it to be energised, and the magnetic polarity of the juxtaposed magnetic core faces must be the same, in order to effect the repulsive action required to produce the rotary motion.

Referring to **Fig.5** and **Fig.6**, the repulsion action causes the rotor to move 13.33 degrees clockwise, while electromagnets **91**, **91a** and **91b** move away from electromagnets **117**, **117c** and **117e** to bring electromagnets **121**, **121a** and **121b** into respective alignment with electromagnets **120a**, **120d** and **120f**. At this time, a capacitor discharge across a spark-gap into their coils **123** occurs, thus moving the rotor. Another 13.33 degrees ahead, as shown in **Fig.7**, major electromagnets **121**, **121a** and **121b** come into alignment with minor electromagnets **117a**, **117d** and **117f**, at which time a discharge occurs to repeat the repulsion action, this action continuing as long as d-c power is applied to the system to charge the capacitor banks.

**Fig.18** further illustrates the sequencing of the capacitor discharges across appropriate spark gap terminal pairs. Nine single stator coils and three single rotor coils are shown with their respective interconnections with the spark gaps and capacitors with which they are associated for discharge. When the appropriate spark gap terminals are aligned, at the points in the positioning of the rotor assembly for most effective repulsion action of juxtaposed electromagnet cores, the discharge of the appropriate charged capacitors across the associated spark gap occurs through the respective coils. The capacitors are discharged in sets of three, through sets of three coils at each discharge position, as the rotor moves through the rotor positions. In **Fig.18**, the rotor electromagnets are positioned linearly, rather than on a circular base, to show the electrical action of an electric engine according to the invention. These motor electromagnets **201**, **202** and **203** are aligned with stator electromagnets **213**, **214** and **215** at 0 degrees, 120 degrees and 240 degrees respectively. The stator electromagnets are correspondingly shown in a linear schematic as if rolled out of the stator assembly and laid side by side. For clarity of description, the capacitors associated with the rotor operation **207**, **208**, **209** and **246**, **247**, **248**, **249**, **282** and **283**, are arranged in vertical alignment with the respective positions of the rotor coils **201**, **202** and **203** as they move from left to right, this corresponding to clockwise rotation of the rotor. The stator coils **213**, **214**, **215**, **260**, **261**, **262**, **263**, **264**, **265**, **266**, etc. and capacitor combinations are arranged side by side, again to facilitate description.

An insulative disc **236** (shown in **Fig.17** as a disc but opened out linearly in **Fig.18**) has mounted thereon, three gap terminal blocks **222**, **225** and **228**. Each block is rectangularly U-shaped, and each interconnects two terminals with the base of the U. Block **222** has terminals **222a** and **222b**. Block **225** has terminals **225a** and **225b**. Block **228** has terminals **228c** and **228d**. When insulative disc **230** is part of the rotor as indicated by mechanical linkage **290**, it can be seen that terminal U **222** creates a pair of gaps with gap terminals **223** and **224** respectively. Thus, when the voltage on capacitor **216** from charging unit **219**, is of a value which will arc over the air spaces between **222a** and **223**, and between **222b** and **224**, the capacitor **216** will discharge through the coil of electromagnet **213** to ground. Similarly, gap terminal U **225** forms a dual spark gap with gap terminals **226** and **227** to result in arc-over when the voltage on capacitor **217**, charged by charging circuit **220**, discharges into the coil of electromagnet **214**. Also, U-gap terminal **228** with terminals **228c** and **228d**, creates a spark gap with terminals **229** and **230** to discharge capacitor **218**, charged by charging circuit **221**, into coil **215**. At the same time, rotor coils, **201**, **202** and **203** across gaps **201a - 204**, **202b - 205** and **203c - 206** each receives a discharge from respective capacitors **207**, **208** and **209**.

When the electromagnet coils **213**, **214** and **215** and **201**, **202** and **203** are energised, the repulsion action causes the rotor assembly to move to position 2 where a new simultaneous group of discharges occurs into rotor coils **201**, **202** and **203** from capacitors **246**, **248** and **282** across gaps **201a - 240**, **202b - 242** and **203c - 244**. Simultaneously, because gap-U-elements **222**, **225** and **228** have also moved to position 2 with the rotor assembly, capacitor **261** is discharged through electromagnet coil **260**, capacitor **265** is discharged through electromagnet coil **264**, and capacitor **269** is discharged through electromagnet coil **268** in alignment with position 2 of the rotor electromagnet coils, thus to cause the rotor electromagnets to move to position 3 where the discharge pattern is repeated now with capacitors **247**, **249** and **283** discharging through the rotor electromagnet coils **201**, **202** and **203**, and the capacitors **263**, **267** and **281** discharging respectively through stator electromagnet coils **262**, **266** and **280**.

After each discharge, the charging circuits **219 - 221** and **272 - 277** for the stator capacitors, and **210 - 212** and **284 - 289** for the rotor capacitors, are operated continuously from a battery source as described earlier with reference to **Fig.1**, to constantly recharge the capacitors to which each is connected. Those versed in the art will appreciate that, as each capacitor discharges across an associated spark gap, the resulting drop in potential across the gap renders the gap an open circuit until such time as the capacitor can recharge to the arc-over level for the gap. This recharge occurs before a rotor element arrives at the next position in the rotation.

The mechanical schematic diagram of **Fig.17**, further clarifies the operation of the spark-gap discharge programming system. A forward disc **236** of an electrically insulative material, has thereon the set of U-shaped gap terminal connectors previously described. These are positioned at 0 degrees, 120 degrees and 240 degrees respectively. In **Fig.17**, schematic representations of the position of the coil and capacitor arrangements at the start of a cycle are shown to correspond to the above description with reference to **Fig.18**. Accordingly, the coil and capacitor combinations **213/216**, **214/217** and **215/218** are shown connected with their gap terminals, respectively, **223/224**, **226/227** and **229/230**. On the rotor coil and capacitor connection, three separate discs **291**, **292** and **293** are shown, each with a single gap terminal. The discs **291 - 293** are rotated so as to position their respective gap terminals 201a, 201b and 201c, at 120 degree increments, with the 0 degrees position corresponding to the 0 degrees position of U-gap terminal **222** on disc **230**.

Representative gap terminals are shown about the peripheries of discs **230**, **291 - 293** to indicate clearly how, as the discs turn in unison, the gap alignments correspond so that three rotor coils always line up with three stator coils at 120 degree intervals about the rotary path, producing an alignment every 40 degrees, there being nine stator coils. Thus, there are three simultaneous discharges into stator coils and three into rotor coils at each 40 degree position. Nine positions displaced 40 degrees apart provide a total of 27 discharge points for capacitors into the rotor coils and 27 discharge points for capacitors into the stator coils in one revolution of the rotor.

It will be understood that, as illustrated in **Fig.17** and **Fig.18**, nine individual electromagnet coils are shown in the stator and three in the rotor, in order to show in its simplest form, how the three rotor electromagnets are stepped forward from alignment with three of the stator electromagnets, when the appropriate spark gaps are in alignment, to effect the discharge of capacitors through juxtaposed pairs of rotor/stator electromagnets. The repulsion moves the rotor electromagnet from the stator electromagnet to the next alignment position 40 degrees further on. In the interval, until another rotor electromagnet, 120 degrees removed, is aligned with the stator electromagnet which had just been pulsed, the associated capacitor is recharged. Thus, the rotor moves from one position to the next, with capacitor discharges occurring each 40 degrees of rotation, a total of nine per revolution. It should be obvious that, with other rotor/stator combinations, the number of electromagnet coincidences and spark-gap discharges will vary. For example, with the coil pairs shown in **Figs 4 through 8**, a total of 27 discharges will occur. Although there are 18 stator electromagnets and 3 rotor electromagnets, the discharge pattern is determined by the specific spark gap arrangement.

The rotor/stator configuration of **Fig.5** and **Fig.8**, involving the major and minor pairs of electromagnets, such as **85a** and **104a** (the terms "minor" and "major" referring to the difference in size of the elements), include nine pairs of electromagnets in the stator, such as **104a**, with three electromagnet pairs of the rotor, such as **85a**. Because of the 13.33 degree separation between the major and minor electromagnets in the rotor pair **85a**, with the same separation of minor and major electromagnets of the stator pair **104a**, the sequence of rotation and discharge described above, with respect to the illustrative example of **Fig.5**, involves the following:

1. A minor element **117** of stator pair **104a** is aligned with the minor element **91** of rotor pair **85a**. On the discharge, this moves the rotor ahead 13.33 degrees.
2. the major rotor element **122** of the pair **85a**, now is aligned with the major stator element **120b** of the next stator electromagnet pair, in the stator array as shown in **Fig.6**. On the discharge, the rotor moves ahead 13.33 degrees.
3. This brings the minor rotor electromagnet **91** into alignment with the major stator electromagnet **120b** of pair **104d**, and the major electromagnet **122** (just discharged) of pair **85a** into alignment with minor electromagnet **117b** of pair **104d**, and the rotor spark gap elements into alignment with a different position of gap elements connected with capacitors not discharged in the previous position of the rotor. It should be remembered at this point that it is the positioning of a rotatable spark gap array, similar to that illustrated in **Fig.17** and **Fig.18**, which controls the time of discharge of capacitors connected to these gap terminals. Therefore, any electromagnet

can be energised twice, successively, from separate capacitors as the rotor brings appropriate gap terminals into alignment with the coil terminals of a particular electromagnet.

Thus, although major electromagnet **120b** of pair **104d** has just been energised as described above, it can now be energised again along with minor rotor electromagnet **91** in step 3, because the rotor moved to a new set of terminals of the spark gap arrays connected to capacitors which have not yet been discharged. These capacitors now discharge through rotor electromagnet **91** and stator electromagnet **120b**, causing the rotor to move ahead another 13.33 degrees, thus again aligning two minor electromagnets again, these being **117b** of stator pair **104d** and **91** of rotor pair **85a**. The rotor has now moved 40 degrees since step 1 above. The sequence is now repeated indefinitely. It is to be noted that at each 13.33 degree step, the discharges drive the rotor another 13.33 degrees. There are 27 steps per revolution with nine stator coil pairs. The discharge sequence is not uniform, as is shown in Table 1. In the stator, three major electromagnets 120 degrees apart are energised twice in sequence, followed by a hiatus of one step while three minor electromagnets of the stator, 120 degrees apart, are energised during the hiatus. In the rotor the major electromagnets are energised during a hiatus step following two minor electromagnet energisation steps. A total of 27 energisations are this accomplished in the nine pairs of coils of the stator.

In Table 1, the leftmost column shows the location of each rotor arm **85**, **86** and **87** at an arbitrarily selected step No. 1 position. For example, in step 1, rotor arm **85** has a minor stator and minor rotor electromagnet in alignment for capacitors to discharge through them simultaneously at the 13.33 degree position.

TABLE I

CAPACITOR DISCHARGE SEQUENCE FOR ONE REVOLUTION OF ROTOR IN SYSTEM OF FIGS. 5 AND 8								
Step No.	Rotor Arm			Rotor Electro-magnet		Stator Electro-magnet		
	87	85	86	Angle	Minor	Major	Minor	Major
10	1	19	13 1/3°	x			x	
11	2	20	26 2/3°		x			x
12	3	21	40°	x				x
13	4	22	53 1/3°	x			x	
14	5	23	66 2/3°		x			x
15	6	24	80°	x				x
16	7	25	93 1/3°	x			x	
17	8	26	106 2/3°		x			x
18	9	27	120°	x				x
19	10	1	133 1/3°	x			x	
20	11	2	146 2/3°		x			x
21	12	3	160°	x				x
22	13	4	173 1/3°	x			x	
23	14	5	186 2/3°		x			x
24	15	6	200°	x				x
25	16	7	213 1/3°	x			x	
26	17	8	226 2/3°		x			x
27	18	9	240°	x				x
1	19	10	253 1/3°	x			x	
2	20	11	266 2/3°		x			x
3	21	12	280°	x				x
4	22	13	293 1/3°	x			x	
5	23	14	306 2/3°		x			x
6	24	15	320°	x				x
7	25	16	333 1/3°	x			x	
8	26	17	346 2/3°		x			x
9	27	18	360°	x				x

Similarly, in step 1, rotor arm **86** is at the 133.33 degree position which has two minor electromagnets in alignment, ready for discharge. Simultaneously, rotor arm **87** is at the 253.33 degree position with two minor electromagnets aligned for capacitor discharge. The other steps

of the sequence are apparent from Table 1, for each position of the three rotor arms at any step and the juxtapositions of respective stator and rotor electromagnet elements at that position.

In the simplified motor arrangement shown in schematic form in **Fig.18**, with single electromagnet configuration, the alignment is uniform and the discharge sequences follow sequentially.

As mentioned before, a change in speed is effected by displacing the stator spark gap terminals on the rotor (shown at **236** in **Fig.17** and **Fig.18**) either counterclockwise or clockwise 6.66 degrees so that the discharge position of the stator electromagnets is displaced. Referring to **Figs. 11 to 15**, the simultaneous discharge of selected capacitors into the displaced electromagnets results in a deceleration if the rotor electromagnet is approaching the stator electromagnet at the time of discharge, or an acceleration if the rotor electromagnet is leaving the stator electromagnet at the time of the discharge pulse. In each event, there is a repulsive reaction between the stator and rotor electromagnets which effects this change in speed.

Referring to **Fig.11**, clutch mechanism **304** about shaft **111** is operated electromagnetically in conventional manner, to displace the spark-gap mechanism **236** which is operated normally in appropriate matching alignment with the rotor spark-gap discs **291, 292** and **293**. Clutch **304** has a fixed drive element **311**, containing an electromagnetic drive coil (not shown) and a motor element **310** which, when the electromagnetic drive coil is energised, can be operated by a direct current. The operation of motor element **310**, brings into operation, spark gap elements **224r, 223r** or **223f, 224f** of the system shown in **Figs. 4, 5** and **8**, as illustrated in **Fig.19**.

The fixed stator coil spark gap terminal pairs **223, 224** and **266, 267** are arrayed about a cylindrical frame **322** which is fabricated in insulative material. In the illustrative example of **Fig.17** and **Fig.18**, there are nine such spark gap terminal pairs positioned around the periphery of the cylinder frame **324**. In the engine of **Figs. 4 to 8**, a total of 27 such spark gap pairs are involved. In addition, although not shown in the drawing, there are also pairs of terminals, such as **223r** or **223f, 224r** or **224f** and **226r** or **226f, 267r** or **267f**, displaced 6.66 degrees on either side of the pairs **223, 224** or **266, 267** and all other pairs in the spark gap array, the letters "r" and "f" denoting "retard" or "faster". The latter displaced pairs are used in controlling the speed of the engine rotor. The displaced pairs not shown are involved in the operation of the clutch **304**, the speed-changing control element.

Clutch **304** is associated with shaft **111** in that the movable element **310** draws clutch disc element **316** on shaft **111**, away from clutch disc element **322** when energised by a voltage of appropriate polarity applied to its motor electromagnet **311**. Such clutch drives are well known in the art.

The clutch mechanism **304** of **Fig.11** and **Fig.19**, when not energised, is in the configuration shown in **Fig.11**. The energised configuration of clutch **304** is not specifically illustrated. Upon energisation, spark-gap element **222** on disc **236** is displaced rightward, as viewed in **Fig.11**, by broken lines **236X**, into alignment with the positions of fixed spark-gap terminals **223f, 224f** and **267r, 266r**. When the disc is in position **236X**, the flattened edge **332** of pin **330** in disc **325** rides on surface **350** of disc **322**. Normally, the flattened edges **351** of pins **330** are engaged against the flat edge **352** in recess **331** of disc **322**. The displacement of disc **322** on shaft **111** is effected by the action of clutch **304** against spring **314** (**Fig.11**). An electric switch (not shown) of clutch mechanism **304** energises it from a d-c power source, and has two positions, one for deceleration and one for acceleration. In either position, clutch **304** is engaged to pull clutch disc **322** from clutch disc **325**, momentarily. For the decelerate or the accelerate position, the displaced alignment of spark gap elements **222** is with the **224f, 223f** and the **224r, 223r** spark-gap terminal elements. However, only the **224f, 223f** spark-gap elements are switched into operation with appropriate capacitors for the accelerate position, while in the decelerate position, only the **223r** and **224r** spark-gap elements are switched into the circuit with their associated capacitors.



Of course, when insulative disc **236** is displaced by clutch **304**, its gap terminals **222**, **225** and **228** (**Fig.14** and **Fig.18**) are all displaced into the alignment position of **236X** so as to engage the "r" and "f" lines of fixed spark gap elements. Although the accelerate and decelerate positions of disc **236** are the same, it is the switching into operation of the **223**, **224** or **266**, **267** exemplary "r" or "f" pairs of terminals which determines whether the rotor will speed up or slow down.

The momentary displacement of clutch disc **322** from clutch disc **325** results in rotation of disc **325** about disc **322** through an angle of 120 degrees. The detent ball and spring mechanism **320**, **321** in disc **325**, positions itself between one detent dimple **328** and a succeeding one **328** at a position 120 degrees away on disc **325**.

As stated, flat **332** of pin **330** rides on surface **350** of disc **322**, and pin **330** leaves the pin-holding groove **331/352** along ramp **333** in disc **322** during the momentary lifting of disc **322** by clutch **304**. Pin **330** falls back into the next groove **331** at a point 120 degrees further on about disc **322**. Pin **330** falls into place in groove **331** on ramp **334**. Pins **330** are rotatable in their sockets **353**, so that for either clockwise or counterclockwise rotation, the flat **351** will engage the flat **352** by the particular ramp it encounters.

The deceleration or acceleration due to the action of clutch **304** thus occurs within a 120 degree interval of rotation of disc **325**. During this interval, disc **322** may only move a fraction of this arc.

There has been described earlier, an electromotive engine system wherein at least one electromagnet is in a fixed position and a second electromagnet of similar configuration is juxtaposed with it in a magnetic polarity relationship such that, when the cores of the electromagnets are energised, the juxtaposed core faces repel each other. One core being fixed, and the second core being free to move, any attachments to the second electromagnet core will move with it. Hence, if a plurality of fixed cores are positioned about a circular confining housing, and, within the housing, cores on a shaft are free to move, the shaft is urged rotationally each time the juxtaposed fixed and rotatable cores are in alignment and energised. Both the fixed and the movable cores are connected to spark gap terminal elements and the associated other terminal elements of the spark gaps are connected to capacitors which are charged to high voltage from pulsed unipolar signal generators. These capacitors are discharged through the electromagnets across the spark gaps. By switching selected groups of capacitors into selected pairs of spark gap elements for discharge through the electromagnets, the rotor of the circular array systems is accelerated and decelerated.

By confining a fixed electromagnet array in a linear configuration, with a linearly movable electromagnet to which a working tool is attached, exciting the juxtaposed pairs of electromagnets by capacitor discharge, results in the generation of linear force for such tools as punch presses, or for discharging projectiles with considerable energy.

### **CLAIMS:**

1. An electric engine comprising:

A housing;

An array of electromagnets uniformly spaced in said housing to form a stator;

A rotor cage on a shaft journaled in and rotatable within said stator, said rotor cage having thereon a spaced array of electromagnets similar to said stator electromagnets and in number, comprising an integral fraction of the number of electromagnets in said stator array;

Each of the electromagnets of said stator and of said rotor, having a core which can be magnetised and of a particular configuration and each being wound with a coil such that a pulses of unidirectional electric current through said coil, magnetises the respective core thereof to a particular magnetic polarity, and the faces of rotor cores juxtaposing selected stator cores are magnetised to the same polarity, the juxtaposed cores thereby tending to repel one another, one lead of each of the stator and rotor coils being connected to a common terminal, the other lead of each of said coils being connected to a gap terminal, the gap terminals of said rotor coils being on the rotor and equal in number to the number of coils thereon and matching the positions of said rotor electromagnets thereon, the gap terminals of said stator being equal in number to the number of coils on the stator and disposed uniformly about said stator to match the positions of said stator electromagnets within said housing;

A first array of capacitors, each having a terminal in common with the common coil terminal of said stator electromagnets, and each capacitor having its other terminal connected to a gap terminal arrayed adjacent the gap terminal of an electromagnet associated therewith;

A second array of capacitors, each having a terminal in common with said common terminal of said rotor electromagnet coils but equal in number to the number of capacitors in said stator array, the other terminals of said capacitors in said second array being connected to gap terminals arrayed about said housing so as to be in axial alignment with said stator gap terminal positions and being alignable with said rotor gap terminals as said rotor is rotated in said housing and respective gap terminals of said rotor coils pass each second array capacitor gap terminals at a predetermined gap distance;

Gap coupling terminals on said rotor equal in number to the number of rotor electromagnet coils and positioned to match the rotor electromagnet positions on said rotor, the gap coupling terminals being rotatable with said rotor so as to pass said adjacent stator coil and associated stator capacitor gap terminal at a predetermined distance therefrom;

A plurality of capacitor charging circuits connected respectively across each of said capacitors in both said first and said second arrays of capacitors for charging each of said capacitors to a predetermined high d-c potential;

A first source of unidirectional electric potential connected to each of said capacitor charging circuits for energising said charging circuits; and

A second unidirectional electric potential source connected to said electromagnets of said rotor and said stator of such polarity as to receive a charge from the inverse inductive discharge of the electromagnet coils as their fields collapse following the discharge of each capacitor through a rotor or stator electromagnet coil,

Whereby, whenever a rotor electromagnet is aligned opposite a stator electromagnet, the rotor coil gap terminal of that electromagnet is opposite an associated second capacitor array gap terminal, and a gap coupling terminal of said rotor is aligned opposite the stator electromagnet coil gap terminal and associated first capacitor gap terminal, the capacitors discharge the charge thereon across the gaps through their associated electromagnet coils to magnetise their respective juxtaposed electromagnet cores to cause them to repel one another, thus aligning a succeeding pair of rotor and stator electromagnets for capacitor discharge across their respective gaps, to cause them to repel one another, alignments rotor rotation within the housing continuously bringing successive rotor-stator electromagnets into alignment for discharge of the capacitors through them to produce continuous rotary motion of the rotor on said rotor shaft, so long as energy is applied to said charging circuits to recharge said capacitors after each discharge.

**2.** In an electric engine having a rotor comprising electromagnetic coil means rotatable within a stator comprising similar electromagnetic coil means, said electromagnetic coil means being polarised for magnetic repulsion;

Capacitor means electrically coupled across successive spark gaps to selected ones of said stator and all of the coils of said rotor;

Charging means connected to said capacitor means for charging said capacitor means to an electrical charge potential sufficient to cause arcing across said spark gaps to result in the discharge of said capacitor means through the electromagnetic coil means repel one another; and

A unidirectional electric power source connected to said charging means to energise said charging means to continue charging said capacitor means following each discharge whereby the rotor of said engine is maintained in rotation by the successive discharges of said capacitor means across successive spark gaps into said electromagnetic coil means.

**3.** An electric engine according to claim 2, wherein:

The charging means includes electronic square core oscillators connected to said unidirectional electric power source and includes step-up means and a rectifier to produce a substantial voltage step up from the voltage of said power source.

**4.** An electric engine according to claim 2, wherein:

The charging means includes a vibrator connected to said power source, and step-up transformer and rectifier means to provide a high voltage for charging said capacitor means.

**5.** A motive force-producing means comprising:

At least a first electromagnet means including at least one coil wound about a core,

At least a second electromagnet means including at least one coil wound about a core similar to said first core,

The respective cores being positioned adjacent to one another so that the magnetic polarities of the adjacent core surfaces are the same when a unidirectional electric current is passed through the coils,

At least one capacitor means having one terminal thereof connected to one terminal of both of said electromagnet coils,

The other terminal of said capacitor means being connected to one terminal of a spark gap means, the other terminals of the coils of both said first and said second electromagnet means being connected to the other terminal of said spark gap means,

At least one unidirectional pulse charging means connected to said capacitor means to charge said capacitor means to a relatively high potential sufficient to arc across said spark gap means at predetermined spacing of said gap terminals, and

A source of unidirectional potential connected to said charging circuit to energise said charging means,

Whereby upon application of current from said potential source to said charging means the successive pulses generated thereby charge said capacitor means to a voltage level sufficient to

arc across said spark gap means to produce a discharge path for said capacitor means through said coils to cause said electromagnet means to repel one another with a substantial force.

**6.** A motive force-producing means according to claim 5, wherein:

Said first electromagnet means is secured in a relatively stable housing, and said second electromagnet means is connected with and freely movable relative to said stable housing, and has utilisation means connected thereto for performing work therewith when said capacitor means discharges through said coils of said electromagnet means.

**7.** A motive force-producing means according to claim 6, wherein said utilisation means is a motor rotor coupled with said second electromagnet means and said first electromagnet means is a stator.

**8.** A motive force-producing means according to claim 6, wherein said utilisation means is a piston attached to said second electromagnet means and is movable therewith to produce hammer-like blows when said capacitor means discharges through said electromagnet means.

**9.** In an electromotive force-generating system as disclosed, means for accelerating or decelerating the motion of a force-generating system, said means comprising:

At least two juxtaposed electromagnetic core elements, one fixed and one movable, including coils wound around it to provide a repulsion tendency when said cores are energised,

Spark gap terminals connected with said coils,

Capacitor means connected with said spark gap terminals to discharge across said spark gap terminals through said coils when a charge of sufficient voltage level appears across said capacitor means, thus to energise said juxtaposed electromagnets to induce said juxtaposed electromagnet cores to repel one another,

Charging means connected to said capacitors for charging them to said sufficient voltage level, and selective positioning means coupled with said spark gap terminals and with at least said movable electromagnet core to cause selective displacement of said movable core with respect to said fixed core.

**10.** An electromotive force-generating system according to claim 9, wherein:

Said juxtaposed electromagnetic cores include a plurality of fixed cores and a smaller number of movable cores, said smaller number being an integral fraction of the number of fixed cores, and

Said selective positioning means is an electromagnetic clutch coupled with said smaller number of movable cores for movement therewith, and includes selective displacement means coupled with said spark gap terminals connected with said capacitors in said capacitor means and selected combinations of coils in said plurality of fixed electromagnets.

**11.** The method of generating motive power comprising the steps of:

**a.** positioning similar electromagnets in juxtaposed relationship with their respective cores arranged for repulsion when said electromagnets are energised,

**b.** charging capacitors to a relatively high potential, and

**c.** discharging said capacitors simultaneously through said electromagnets across spark gaps set to break down at said relatively high potential, thereby to cause said similar electromagnets to repel one another with considerable force.

**12.** The method of generating motive power defined in claim 11, wherein, in said positioning step at least one of said electromagnets is maintained in a fixed position and another electromagnet is free to move relative to said fixed electromagnet.

**13.** The method of generating motive power according to claim 11, wherein:

The charging step includes the charging of capacitors to a relatively high potential from a pulsed unipolar source of electrical energy.

**14.** in an electromagnetic capacitor discharge engine including movable electromagnets and fixed electromagnets, said movable electromagnets being movable into polar alignment with said fixed electromagnets, capacitor means, means for charging said capacitor means, and means for discharging said charged capacitor means through said fixed and movable electromagnets to polarise aligned fixed and movable electromagnets for magnetic repulsion, an acceleration and deceleration control means comprising:

First selective means for momentarily delaying the discharge of the capacitors until the movable electromagnets in said engine have begun to recede from the fixed electromagnets, in order to accelerate the motion of said movable electromagnets by the added impetus of the repulsion, and

Second selective means for momentarily accelerating the discharge of the capacitors to occur at a point in the motion of the movable electromagnets where said movable electromagnets are approaching said fixed electromagnets to decelerate the motion of said movable electromagnets by the tendency to repel the approaching electromagnets by the fixed electromagnets.

**15.** An electric engine, comprising:

Fixed electromagnets;

Movable electromagnets, movable into alignment with said fixed electromagnets;

Capacitor means;

Means for charging said capacitor means, and

Means for discharging said charged capacitor means through said fixed and movable electromagnets to polarise said aligned fixed and movable electromagnets for magnetic repulsion.

**16.** An electric engine as recited in claim 15, wherein: said means for discharging said charged capacitor means comprises voltage breakdown switch means.

**17.** An electric engine as recited in claim 16, wherein:

Said voltage breakdown switch means includes at least one terminal movable with at least one of said movable electromagnets for breaking down when said at least one of said movable electromagnets is in alignment with a said fixed electromagnet.

**18.** An electric engine as recited in claim 17, wherein:

Said voltage breakdown switch means comprises a spark gap means.