

Passive Cooling

Part II — Applied Construction

Cliff Mossberg

©2001 Cliff Mossberg

In Part 1 of this series (see *HP82*, page 84), I outlined the three modes of heat transfer, and tried to integrate this knowledge with the factors of human comfort. This information is basic to any design or construction geared towards minimizing the discomfort of living in the tropics.

In Part 2, I would like to show some of the design techniques for dealing with the effects of heat and humidity in a dwelling located in what we know as “the humid tropics.” This label differentiates this climate from that of a hot, arid, desert type of environment. The desert might ultimately be hotter than the conditions found in the humid tropics. But the low humidity found in the desert makes it practical to use some techniques of dealing with the heat that we cannot use in more humid locations.

Figure 1: Seasonal Variation of the Solar Path

For Barton Creek, Belize, approximately 17° North Latitude

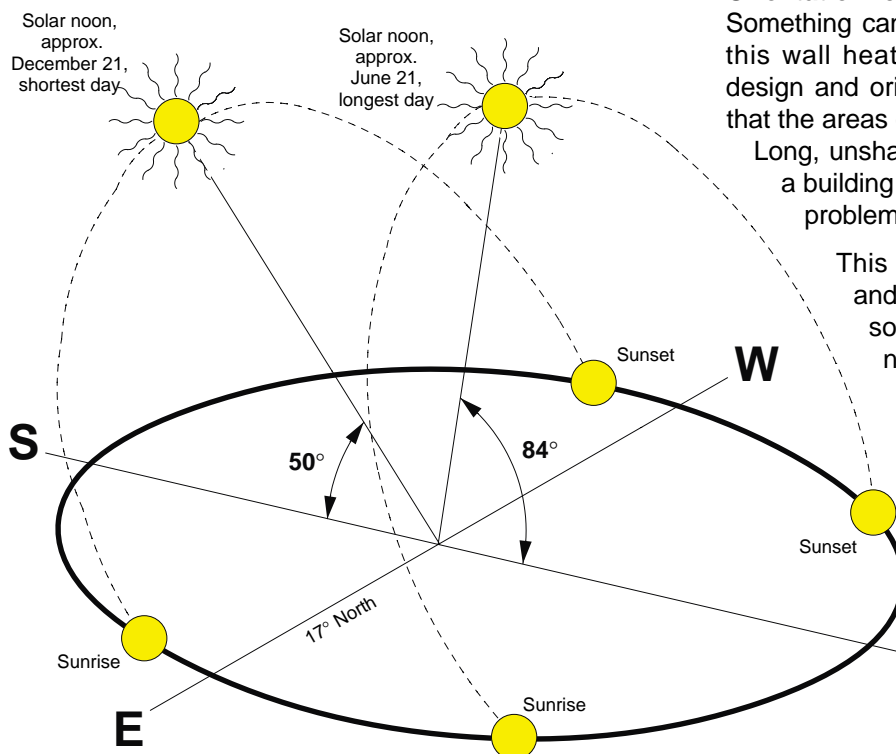

Solar Incidence as a Design Element

The sun is the primary engine of heat gain in a tropical dwelling. It is not usually ambient air temperature that causes heat discomfort, but the radiant energy of sunlight, either directly or re-radiated in long wave infrared. The first line of defense against heat buildup in a building is to minimize the surfaces that sunlight can fall on.

It is obvious that the building's roof is going to be the main absorber of solar energy. If the roof is designed to block heat flow down into the dwelling, and made large enough to cover and shade the walls, the builder should be successful at reducing unwanted heat. This simple concept is more difficult to accomplish that it seems at first.

If the sun was always in the high-noon position, the job would be simple, but it's not. In the morning, it starts out shining low in the eastern sky. It can heat up a building's walls for many hours before it rises high enough for the roof's shadow to shield the east wall from radiant energy. In the afternoon, the sinking sun has the same effect on the western wall.

Orientation for Minimum Incidence

Something can be done at the design stage to reduce this wall heating. The very first effective step is to design and orient the structure on the building site so that the areas of the east and west walls are minimized.

Long, unshaded walls on the east and west sides of a building can significantly contribute to the heating problem.

This problem is not as severe on the north and south walls. The sun will be lower in the southern sky in winter when wall heating is not as big a problem. But the sun will never be as low in the southern sky as it is near sunrise and sunset in the east and west, so engineering roof overhangs to block the southern sun is much easier.

Roof Overhangs

In Figure 2, angle A represents directly overhead. Angle B has its pivot point at the base of the south wall. It is plotted at the local angle of north latitude. At that angle, the sun would appear

Figure 2: Angles of the Sun and Cast Shadows

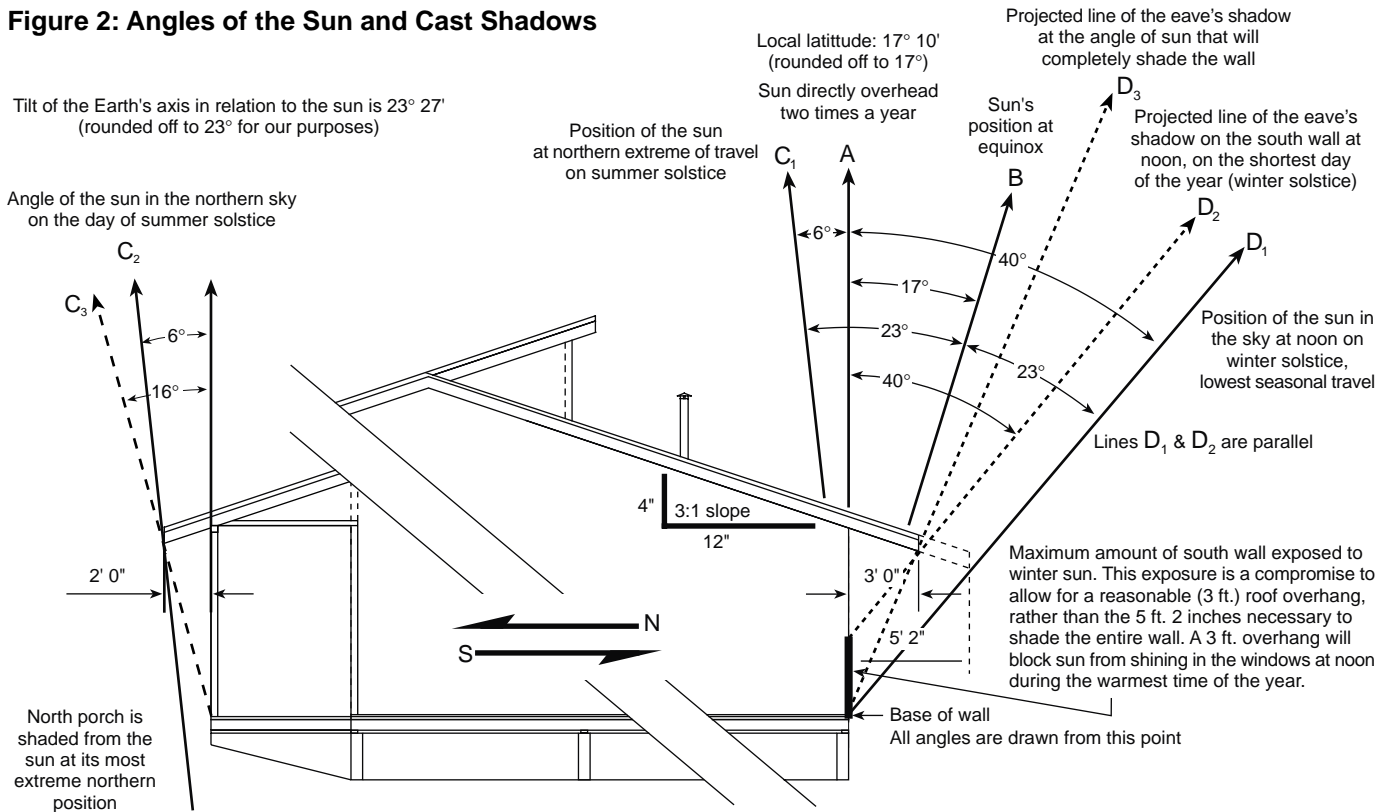

directly overhead at the equator on the days of the solar equinox. **A** is easy to find—it is straight up. **B** is easy to compute graphically once local latitude is known. Once you have **B**, you have a baseline.

If we swing an angle north 23° from **B**, we will have the northernmost angle of the sun's travel in the sky in Belize. In this case, it is an angle of 6° north of vertical, or 84° vertical declination from level ground, pointing north (Figure 1). I have labeled this line C_1 . If C_2 is drawn at the exact same angle as C_1 , but touching the edge of the roof overhang on the north wall, the lower extension of C_2 will indicate the path of the sun's rays on the north side of this building.

In this case, the sun will not ever touch the base of the north wall. C_3 is the position the sun would have to travel to for it to begin to heat the base of the wall. C_3 is an imaginary angle, since the sun is never that far down in the northern sky at this time of day and this location in Belize. This shows us that a standard 2 foot (0.6 m) overhang on the north edge of the roof is sufficient to shade this north wall at all times of the year at this location.

Returning to our baseline **B**, we need to turn another 23° angle, south from **B** this time, just as we turned north before. This will produce line D_1 , the angle of the sun's rays at its extreme southern sky position. It is immediately obvious that D_1 does not touch both the

base of the south wall and the edge of the roof overhang. We know from this that the roof overhang is insufficient, even at 3 feet (0.9 m), to completely shade the south wall.

The south roof overhang would have to be extended all the way out to 5 feet 2 inches (1.6 m) to completely shade the wall. This large overhang would be structurally weak in high winds, and would also hang down far enough to block the view out of windows on the south wall. A compromise between 100 percent shade, vision, and structural rigidity will be necessary.

There are at least two possible solutions to this need for compromise. In Figure 2, I have chosen to construct D_2 as a line parallel to D_1 but moved over enough so that it touches the south roof overhang. If it is extended down to intersect the wall, the lower projection of D_2 represents the limit of the south wall shading. Above the intersection with the wall will be shaded; below will see direct sun at this time of the year. The line of shade appears here to be sufficient to keep the sun's rays out of the window openings.

Vegetation

Trees and shrubs that shade the structure are one approach to blocking sunlight. From a practical standpoint, it is difficult and extremely expensive to add mature trees of any size to a building design. The usual procedure is to plant smaller ones and tolerate the sun



A wall of decorative concrete block allows ventilation and provides shade, transmitting only muted light.

until the smaller trees are big enough to produce shade. Unfortunately this can take ten years or longer. Where possible, keep what you have.

Vining plants are a good alternative to trees, with one serious caveat. One of the goals of a tropical house design is the exclusion of termites from the wooden parts of the structure. This can be done by building elevated columns with termite collars on top. Any vegetation planted on the ground and close enough to the structure to touch it will provide a path for termites to circumvent the exclusion features of the design. Without the termite problem, it would be effective to use a trellis on the east and west walls. Vining plants such as passion fruit can intercept the sunshine and put it to good use growing flowers or edibles.

Wall Shading with Architectural Elements

It is possible to use architectural elements to moderate direct sun on the walls. Properly designed architectural screens can be made to block and modulate sunlight to good advantage. The photo above illustrates the use of such a screen, here composed of simple decorative concrete blocks placed together into a pleasing texture. This very effectively opens up a whole wall to air and muted sunlight.

This screen can conceal wooden or metal louvers fitted with insect screens. These can be opened for the warm dry weather, but closed for storms. In this design, the concrete screen is integrated as part of an upscale-style Belizian house. It will take a substantial foundation to support such a screen. Such massive architecture is not necessary.

Hassan Fathy describes a traditional screen used throughout the Middle East that is made up of round turned spindles arranged into a rectangular grid. It is known as a mashrabiya. The same term is used to describe vertical louvered blinds that can be adjusted to shade an entire wall.

Both of these devices allow conditioned light to enter the building for illumination, while blocking the strong exterior sunlight. The harsh contrast of the sun beating on the outside of the screen blocks outsiders from seeing through the screen to the inside. But it allows someone on the inside to easily see out into the bright exterior.

Window Shading Devices

There are two problems to deal with if you wind up with sunshine on your outer walls. There is the re-radiation of the solar energy into the interior from the walls. I'll deal with that next. But first I want to deal more thoroughly with the problem of solar energy directly heating the interior space through the window openings. Where this is a problem, the windows themselves can be constructed to block the sun's rays through reflective glass coatings and through the use of solar screens.

Jalousie windows are commonly used in the tropics. They use single panes of glass to form the louvers. These single panes have virtually no insulation value. In contrast, double and triple pane argon-filled glass used in the colder regions are designed primarily to block conductive and radiant heat flow outward, not to facilitate natural ventilation inward. They would be valuable in an air conditioned house.

While air conditioning has a role in tropical cooling, it is not going to be a factor in our passive design focus. We want to foster good air circulation and a design that excludes solar radiation. Jalousie windows glazed with glass that uses reflective films can do this.

Glass can be made with a permanent reflective coating deposited on one face. This is conventionally either bronze or aluminum in color. This coated glass can block up to 80 percent of the heat energy in incoming sunshine. Films that can be applied to uncoated glass are also available for this purpose, and provide approximately the same excellent result. The downside to reflective coatings is a reduction in the amount of visible light entering a house for general illumination.



Louvered "jalousie" windows are coated with a reflective surface to block sun. They also readily facilitate ventilation.

Solar screens that go on the outside of the windows in place of conventional insect screens are also very effective, reducing the incoming heat energy by up to 60 percent. Using both of these strategies produces a tropical window that is extremely effective at blocking invading radiant energy, while still providing excellent ventilation. The cost is higher than uncoated glass and normal screening, but it is worth the money.

There are many traditional methods available for blocking solar heat from infiltrating the inside of a house through the window openings. As a general rule, external devices such as awnings, louvers, and roll shades are more effective than inside devices such as venetian blinds and roll shades. The efficiency of each device is a function of its material, color, and texture.

Radiant Barriers

The material of choice for blocking both visible light and infrared is a shiny sheet of polished metal. Aluminum foil is one of the best materials, reflecting up to 95 percent of both wavelengths. This foil is a very good conductor of heat energy, but it is a very poor radiator of radiant heat energy. It has a maximum emission inversely proportional to its reflectance.

In English, that means that a highly polished aluminum foil might only re-radiate 5 percent of the radiant heat energy falling on it. It is an ideal blocker of radiant energy. Used in this way, these foils are known as radiant barriers. Under peak sunshine conditions, a radiant barrier can reduce heat inflow by as much as 40 percent or more.

For a radiant barrier to be effective, it must have an air space on one or both sides. Aluminum is a very good conductor of heat. Without this air space, the foil would simply move heat from whatever substance is on one side of it to whatever is on the other. It would do this very efficiently. When it is installed with an adjacent air space, the air (which is a good insulator for heat transfer in the conduction mode) blocks conduction of heat from the foil, while the poor emissivity of the foil blocks heat transfer through the process of radiation.

Roof Design & Radiant Barriers

The roof is the most critical heat blocking device in your arsenal. It can operate passively, blocking radiant energy from moving downward into the house using a

radiant barrier. It restricts conductive flow of heat through the roofing materials. And it can be designed to use thermal convective flow to carry off air heated by the roofing.

The roof design I prefer is actually two roofs sandwiched together. The upper roof blocks wind and rain. It also contains convective air channels (see Figure 3) between spacers over the structural joists. These cavities form ducts so that air heated by the hot roofing can rise and exhaust at the high point through thermal convection. Below these vent channels is a layer of radiant barrier material. This barrier blocks the heat that is radiated by the metal roofing, keeping it out of the dwelling.

Figure 3: Cross Section of a Roof in the Tropics

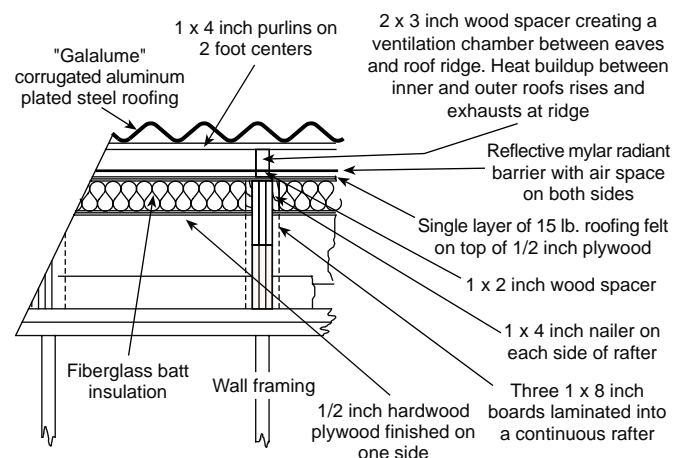

The lower sandwich contains the structure as well as fiberglass batt insulation to block conductive heat flowing downward into the living area. As mentioned in Part I, radiant heating is the principal mode of heat flow downward. Conductive heat does not move as readily downward through materials.

Where the roof is built of standard sheet roofing over rafters, installing the radiant barrier is quite simple. It can be tacked to the underside of the rafters, above the ceiling joists. For this use, radiant barrier is available in several different designs.

Radiant Barrier in the Walls

Walls can also easily incorporate a radiant barrier. Where double-wall construction is used, the barrier material can be installed on the inside with the foil material facing the outer wall. In areas where insulation is to be used in the wall, more care must be taken so that there is an air space between the insulation and the barrier material.

One method of utilizing the radiant barrier material requires that it be installed on the outside of the sheathing. Spacers are then nailed over the barrier material, and a second, vented skin is installed on the outside. Vents at the top and bottom of this second building skin form a solar chimney, allowing heated air to exhaust from the wall by convection. This tactic works with either open single-wall construction or insulated double-wall construction.

Building Insulation

Many materials have been developed to do the job of holding air as an insulator. From sawdust, thatch, and straw, to high tech materials such as aero-gells and ceramic foams, all materials have pros and cons. The first materials I've mentioned are organic, and subject to biological degradation. The second two are ridiculously expensive for home use. Good home insulating materials should be cheap, effective, and stable.

The ideal building insulation is nothing. The nothingness of the vacuum in space is a case in point. Heat flow due to conduction or convection simply cannot occur in a vacuum because it depends on the interaction between molecules of a substance to move the heat. No substance equals no heat movement. But a vacuum is not easily maintained.

Among commonly available materials, air is a very good insulator. It is cheap and efficient, but air has a tendency not to stay in one place when it is heated. We need to stop convective air movements by trapping it.

Stability in Insulation Materials

Many insulating materials are available that do this

successfully. Sawdust is one of the earliest and cheapest insulators. One of the great drawbacks of using sawdust is that it can absorb water from rain or moisture in the air, or even from the building interior. Water absorption will degrade the insulation value, and may lead to bacterial, fungal, or insect damage.

Sawdust is also subject to settling. Even the mechanical vibrations a building may be subject to can cause settling of the sawdust, opening up large cavities above the insulating material where convective heat flow can occur. A good insulator must be more than efficient; it must be stable too, maintaining its original volume and material properties.

Insulation Toxicity

To be a stable building insulator, a material must contain as much air as possible, trapped in a matrix of inert material. Rock wool is one of the oldest commercial insulators available in batt form. It is still used around heating systems where resistance to flame or high heat is desirable.

Rock wool is manufactured from inert materials that have been heated and spun out into fine fibers. It is then fabricated into batts containing innumerable small air spaces. It is a brittle material with friable fibers that can break down easily during handling. These fibers can be a severe irritant to the human body, both to the lungs and to the skin.

So besides being stable, a good building insulator should be benign to the people who must install it and live around it. Asbestos is the classic example of the perfect insulation material that is also supremely toxic.

Materials such as glass wool—fiberglass—and several types of closed-cell foams are non-toxic and non-irritating to a greater or lesser degree. Fiberglass is less benign than other materials, but not nearly as irritating as rock wool.

Fire Retardant Qualities

Another material that is common in the residential building trades is cellulose insulation. This is manufactured out of ground-up paper, frequently newspaper. It has fire retardant added, and sometimes materials to make it resistant to insect damage. Cellulose is a very efficient, non-toxic insulator, but it has a tendency to settle in vertical cavities, just as sawdust does. Because of this, it is primarily used as loose fill above ceilings. If it is kept dry, it works very well.

Foam boards and foamed-in-place urethanes are excellent insulators, but they do not like heat. Under high heat conditions, they can produce toxic gases that are lethal. Under sustained heat conditions such as

those found under a tropical roof, they can break down and outgas, losing their closed-cell foam structure, and seriously degrading their insulation ability.

The material I prefer for insulation in the tropics is glass wool, most commonly known as fiberglass. It is available in the U.S. in either batts or loose fill that can be blown into place. Fiberglass is similar to rock wool in its physical construction. Since it is “spun” out of fine strands of real glass, it is inert to heat, resistant to airborne moisture in the form of high humidity, and is a very effective insulation. It is slightly more physically irritating to handle than some other insulations, but new materials are better than aged materials in this respect.

Shipping Cost

Since all of the commonly accepted thermal insulations are light and bulky, they are expensive to ship long distances. The cost of shipping this type of product is based on its volume rather than its weight. That can be substantial.

Fiberglass suffers from the same drawback that other insulating materials do. It is difficult to obtain in Belize and other tropical areas because it frequently must be shipped in from more developed nations. Many nations place a high customs duty on imported goods such as these.

Where it is available, two-component urethane foam insulation is very convenient because the resin to manufacture it can be shipped by the barrel, in concentrated form. With modest equipment, the two-part resin can be combined and applied directly. It will then expand in place. Keep in mind that this foam does not like high heat.

How Much Insulation?

Some people define “R” values as “resistance” to the flow of heat. This is a good way to think of R-values. R-values can be added together, and they are a directly proportional measure of heat resistance. The chart at right lists common building materials, including insulation materials, and their associated R-values.

Where there is little difference between inside and ambient temperatures, and where air movement through natural ventilation is the goal, uninsulated walls and floors are acceptable. In a temperate climate, where winter heat and summer air conditioning expense is an important factor, a well-insulated house envelope is required. R-values in the floors, walls, and ceilings are specified by the location of the house in specific climate zones.

The type of energy used to heat or cool a building affects recommendations too, with higher R-values specified for electric heat than for fossil fuels, for

R-Values of Common Building Materials

<i>Material</i>	<i>R-Value</i>
<i>Insulation</i>	
Polyurethane, per inch	7.00
Polystyrene, extruded (blue board), per inch	5.00
Polystyrene (bead board), per inch	3.85
Rock wool, per inch	3.45
Fiberglass batt, per inch	3.35
<i>Masonry</i>	
Concrete blocks, 8 inches	1.11
Brick, common, 4 inch	0.80
Concrete blocks, 4 inches	0.71
Stucco, 1 inch	0.20
Concrete, per inch	0.08
<i>Siding</i>	
Wood bevel siding, 3/4 inch	1.05
Wood shingles	0.87
Wood bevel siding, 1/2 inch	0.81
Aluminum siding	0.61
<i>Roofing</i>	
Wood shingles	0.94
Asphalt shingles	0.44
Felt paper, 12 lb.	0.06
<i>Wall Covering</i>	
Insulation board sheathing	1.32
Cement board, 1/4 inch	0.94
Gypsum board (drywall), 5/8 inch	0.56
Gypsum board (drywall), 1/2 inch	0.45
<i>Windows</i>	
Sealed double glazing	1.92
Single thickness glazing	0.91
<i>Wood</i>	
Common construction softwoods, 3-1/2 inches	4.35
Common construction softwoods, 1-1/2 inches	1.89
Common construction softwoods, 3/4 inch	0.94
Plywood, construction grade, 3/4 inch	0.93
Maple, oak, or tropical hardwoods, 1 inch	0.91
Particleboard, 5/8 inch	0.82
Plywood, construction grade, 5/8 inch	0.78
Hardwood finished floor, 3/4 inch	0.68
Plywood, construction grade, 1/2 inch	0.62
Plywood, construction grade, 1/4 inch	0.31
Tempered hardboard, 1/4 inch	0.31
Regular hardboard, 1/4 inch	0.25

example. Additionally, fiberglass batts are only available in certain thicknesses, so recommendations usually adhere to what is available. 3-1/2 inch (9 cm) thick batts are rated R-11, 5-1/2 inches (14 cm) at R-19, etc.

Dead Air Spaces Used as Thermal Blocks

There are other ways of designing to resist heat flow from solar-heated walls besides radiant barriers and insulated surfaces. In new construction, during the design phase, it's necessary to be aware of potential heating problems. It is cost effective to design cabinets, closets, garages, or other unoccupied or infrequently occupied spaces along those walls that are sources of interior heating due to exterior solar radiation. This practice creates a double wall with an interior dead air space to resist heat moving across that space into the living environment.

Mass Used as a Thermal Flywheel

From the adobe pueblos of the southwest Indians to the rock walls in the ancient stone city of Great Zimbabwe, many indigenous forms of architecture have taken advantage of the thermal storage inherent in large mass. This mass can store heat, and can also even out the temperature fluctuations in a hostile living environment. The modern equivalent of these classic examples is the Trombe wall.

Using mass to mitigate temperature swings in a dwelling only works well where the temperature differential between the mass and the tempering heat source is fairly large. If you try to adapt the Trombe wall or other less passive applications of thermal mass storage to cooling in the humid tropics, you are limited by environmental factors.

Solar-driven temperatures inside a poorly designed building can go up to 125°F (52°C) in the heat of the day. This gives you a nice temperature differential to drive heat exchange, but such a gain is never desirable! But you do need a significant temperature difference to move much heat from the hot interior mass to the cooler outside nighttime air. In a passively cooled house in the humid tropics, there is no concentrated source of "cold" that can drive such a cooling heat flow the way there is with solar heating.

Convection

In *Passive Cooling—Part 1*, I covered the theory of convection, the movement of heat carried by the flow of a fluid such as air or water. Here I will try to explain how the designer or builder can use the building envelope to force convective flow to occur passively—without any input of energy other than what is applied to the fluid through natural influences.

I should say here that I do not personally subscribe to the need for *entirely* passive designs. Where the energy

is available or where you can create it efficiently, there are good arguments for the use of active designs. Low voltage DC ceiling fans are a good example.

The key to good design is the word "efficiently." Both passive and active cooling systems can be designed that are so expensive to install that it could well be more efficient, all things considered, to run a generator and an air conditioner. So when I talk about efficiency of design, I am factoring in the overall cost of the design, not just operating costs.

Chimney Effect Ventilation

Hot air is less dense and therefore lighter than cool air. It rises or floats on the heavier, cooler air. As with all forms of heat flow, "hot" and "cold" are qualities that are relative to the temperature of a human body—98.6°F (37°C). There is no absolute quantity known as "hot" or "cold."

The important consideration is the difference in temperature between one heat source and another, not whether it is hot or cold. This concept is known technically as Δt (delta t), shorthand for the change in, or the difference in temperature.

Δt governs all things thermal, including radiation of energy from one hot body to another, conduction through a substance, or how easily hot air will float on cooler air. If Δt is high, hot air is more buoyant and will rise faster. If Δt is small, there is less tendency for a heated mass of air to move upwards. I am using air here as a familiar example, but technically, any fluid from air to water to molten metals will support convective heat flow.

Solar chimneys are structures designed to heat air with solar energy. This heated air then rises in a duct, just as furnace-heated air in a stovepipe rises. Under most conditions, stand-alone solar chimneys cannot justify their cost with their performance. Solar-enhanced ventilators (roof panels that are designed into new construction) may have a slightly better cost/benefit ratio, but as a general rule, their performance is disappointing. They are especially ill-suited to the humid tropics.

Roof Venting

In *Part 1*, I described heat buildup in the attic air space under a hot roof, and I showed how this buildup transfers heat to the ceiling and then down into the living space. If we return to that example, we can now discuss the role convection will play.

In the example above, the hot roof will attain temperatures of around 140°F (60°C) maximum. In the living space, the desirable temperature is around 72°F (22°C). There is a Δt between the roof heat source and

the ceiling of 68°F (20°C). That is sizeable.

Suppose now that we open the roof up and allow the hot air, which has risen to the highest point of the roof, to keep rising and escape? This air removal technique is known as roof venting, and it is highly recommended for any enclosed roof or attic space.

Of course, for air to flow out of a cavity, there must be provision for replacement air to flow in. The hot air flows out, creating a very slight vacuum, which draws cooler air in from some other place, usually around the roof eaves or gables.

As this replaces the hot air with much cooler air, the Δt between the attic air space and the ceiling membrane is considerably reduced. The Δt between the roof and the attic air is increased, allowing more heat to transfer from the roof surface to the attic air, which is vented outside to the ambient air. This reduces the roof temperature. Clearly, convection can be useful.

Whole House Venting

The type of convective heat removal described above is not just useful in attics and roofs. It is also useful for whole house ventilating under certain conditions. The point of whole house ventilation is to completely change the air inside the living envelope periodically.

Large fans are typically used for whole house ventilation in hot climates. These are installed in the ceiling, and thermostatically controlled to respond to overheating of the living space. This is typical for houses without refrigeration-type air conditioning that encounter seasonal high temperatures. For our purposes, we must try to accomplish the same end goal, but without the fan. (When practical, a whole house system is an excellent application for a solar-powered fan.)

Whether you employ a fan or rely only on convection for whole house ventilation, it is desirable to achieve about twenty air changes per hour, or 0.33 air changes each minute. The volume of the structure can be found by multiplying the floor area by the wall height. For the house in Figure 4, it works out to about 6,850 cubic feet (194 m³). So the resulting airflow desired is around 2,260 cubic feet (64 m³) per minute (0.33 x 6,850 = 2,260.5).

Disadvantages of Convection Alone

In Figure 4, the outer wall of the house is around 8 feet (2.4 m) tall, while the roof over the clerestory windows

Figure 4: Ventilation Paths

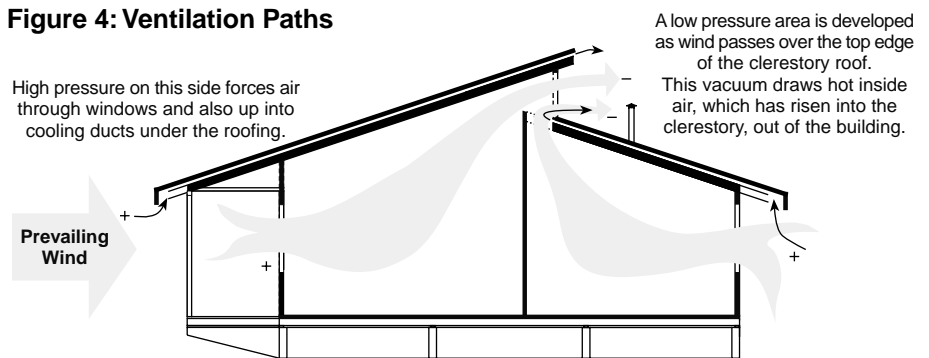

in the center is over 14 feet (4.3 m) tall. The interior of this house has a cathedral ceiling that rises to a high point above the clerestory. Hot air can flow out at this high point to drive whole house venting. Calculating the ventilating airflow under the best of conditions gives about 300 cfm—not very good! Here we are assuming no wind augmentation, just the induced circulation due to hot air rising and exhausting.

The reality is that we are not going to be able to ventilate this dwelling without the help of solar energy. Either we will need it to run an active fan system, or at a minimum to heat up the building so there is differential temperature gain that can be put to work moving air. But the last thing you want to do is introduce hot air just to get rid of the hot air! Convective cooling alone is not possible in this house under these rainy-season conditions. During the dry season, some air exchange is possible using convection.

Buried Cooling Tubes

Another idea that frequently creeps into conversations about passive cooling is the use of earth tubes as air intakes for solar chimney driven ventilation. The principle here is that pipes are buried in the cooler earth to draw air into the structure. The intake air cools down to earth temperature as it is drawn in, cooling the building.

Where a source of forced ventilation is available, such as an electrically driven blower, this can be made to work. Even then, there are potential problems with moisture build-up in the tubes, which can lead to introducing mold and mildew into the structure. Without using a powered blower to force air through the cooling tubes, non-circulation or even reverse circulation (pulling heated air into the structure from a hot source) is a possibility.

It is important to remember that stack-effect ventilation requires that the *average* temperature in the air column be higher than the cooler surrounding air. If the air column is 85°F (29°C) in the dwelling, 100°F (38°C) in

the stack 10 feet (3 m) above, and 70°F (21°C) 10 feet below, down inside the cooling tubes, we have an average column temperature of 85°F. Ambient air temperatures outside would have to be lower than 85°F for upward movement of the air column to occur.

Wind Used for Ventilation

Wind is a form of convective air movement driven by the sun. It is a concentrated form of energy. Every time you double wind velocity, you increase wind energy eight times, because wind energy is a cubic function of velocity.

Wind will act on a building, whether we intend it to or not. Contrary winds can and do drive heated air backwards in solar ventilating ducts. They can allow cold air infiltration into a heated building envelope, and they generally do unexpected things in a structure not well thought out to resist wind dynamics.

Where a reliable breeze is available, you can use it to good advantage to drive air exchange through the envelope of a building. A considerable amount of information is available about how wind interacts with the planes and curves of a building structure.

The U.S. Federal Emergency Management Administration (FEMA) has thoroughly explored the dynamics of wind/structure interaction, seeking a better understanding of hurricane damage to buildings. Figure 5 and 6 are taken from FEMA course material, and illustrate the envelope dynamics of a building very well. This information is basic to understanding how the forces developed by wind can be used to foster local area and whole house ventilation.

Wind blowing against the walls and roof of a building is forced along the planes of the surfaces. When it reaches the limit of a surface—the corner of the wall or the edge or peak of the roof—it continues to blow in the direction in which it has been flowing. This is a property of the inertia of the mass of the air in the wind current.

As it passes the edge of a building panel, wind does not turn the corner and follow the building planes. Instead, it lifts away from those flat sides, creating an area of lower pressure just past the edge. Technically, it makes a transition from smooth laminar flow along the panel to turbulent flow away from the second panel.

Air Flow Around Walls

Figure 5 illustrates wind flow as if we were looking down from above on the floor plan of a rectangular building. On the left is a pictorial schematic of the path of the wind flow. On the right is a schematic diagram of the vector forces of pressure and vacuum induced by the wind pattern on the left. Arrows pointing inward at the wall represent pressure. Arrows pointing outward,

Figure 5: Wind-Induced Pressure Vectors Under Different Conditions of Building Ventilation

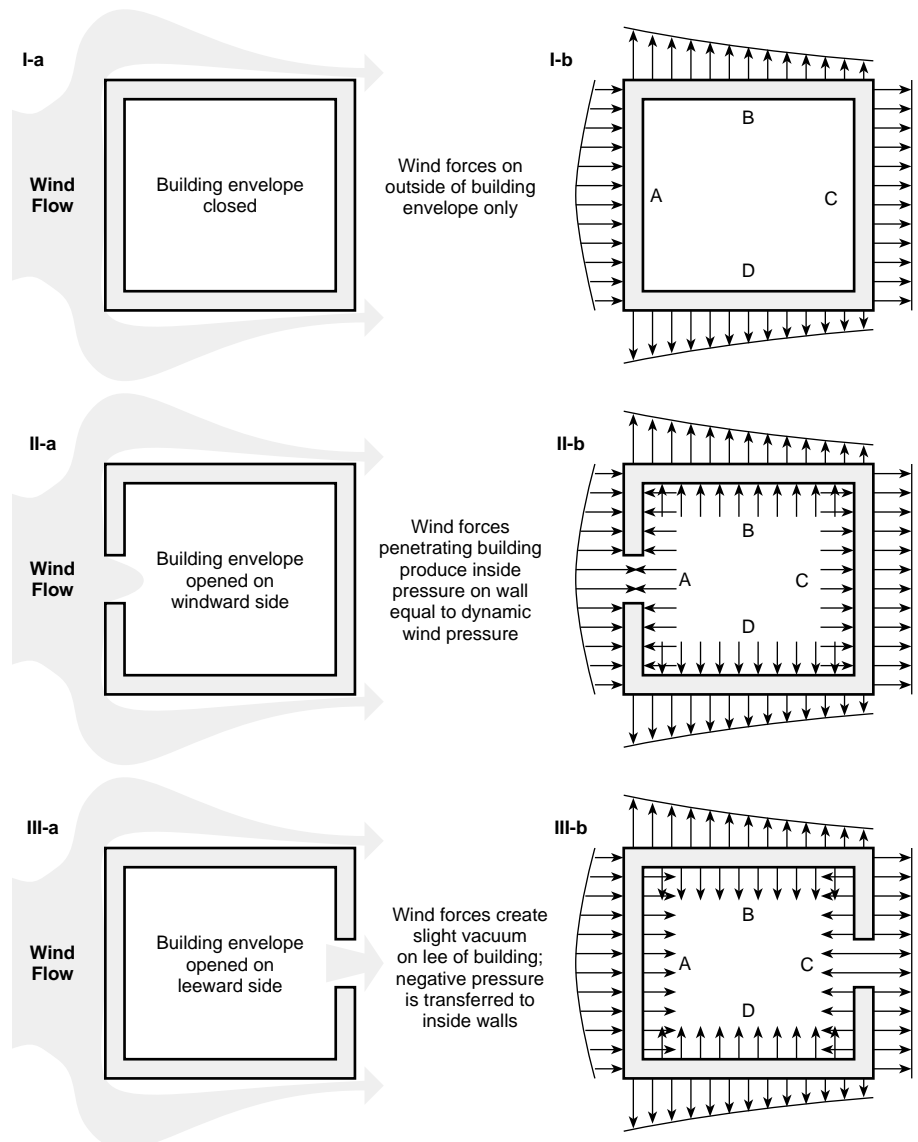

away from the wall, represent vacuum. The curved lines are a rough representation of a graph of the pressure/vacuum forces, showing how they vary in different locations.

Illustrations I-a and I-b in Figure 5 show a building with sealed walls and roof. In this theoretical illustration, there are no paths for pressure to be transmitted into the envelope. Every time a building design creates an impediment to smooth airflow, it will induce a high pressure area. And every time airflow is forced over a hard edge with nothing behind it, a modest vacuum will be created.

Figure 5, illustrations II-a and II-b show a building with a breach in its windward wall. This can be a door, window, or just siding torn off under high wind forces. There are no other openings in the walls, so pressure builds up inside the building until it exactly equals the dynamic force of the wind entering the windward wall. The air is actually compressed somewhat, causing a rise in the static pressure against all of the inside walls.

Once the inside static pressure and the dynamic wind pressure equalize, it is just like a balloon that's been blown up. No more air can blow into the building because it is balanced by the force pushing out by pressure of compression. As II-b illustrates, the pressure inside this building is exactly equal to the highest pressure developed on the windward wall. This is because the wall opening is located in the area of highest pressure.

If the wall opening were moved over to an area with less pressure (near the corner), that lesser pressure would be what is transmitted to the inside of the building. Wall C is subject not only to the force developed by the mild vacuum pulling on the outside, but also to the force of the static pressure inside. These forces add up. In hurricane winds, a building can explode under these forces.

The designer should be sensitive to the areas of wind-induced high and low pressure in a structure. Maximum interior air flow value can be achieved by allowing pressure into a building envelope at points of highest dynamic wind pressure. Conversely, air can be drawn from inside a building most efficiently by strategic placement of exit venting at points where the wind has developed negative pressure. Combining both strategies gives a very effective push/pull effect. It is desirable to have the outflow openings larger than the inflow. A six to one ratio of outflow to inflow area is optimum.

Air Flow Over Roofs

Figure 6 shows buildings in cross section to illustrate the dynamics of airflow over different roofs. The flat roof and the low-pitched gable roof are subject to negative forces trying to lift up on them. Roofs with pitches over 40° do not have sufficiently sharp eaves to cause the flowing air to pull away from the roof as it moves along. Consequently, the windward side of the roof receives a substantial impact from the direct wind. So there are positive pressures on one side of this building, including the roof, and negative pressures on the downwind side.

These are the notes of the tune we want to play. Now we must put the notes together into a melody. If you open a building up to ventilation on the windward side only, you will have no ventilation. The inside and outside pressures cancel each other out, and that's that. This illustrates that you must have both an inlet and an exit for air to flow. Air must flow out of the envelope as fast as it can flow in or there will be pressure build-up that will restrict inflow.

Figure 6: Wind-Induced Pressure Vectors Over Different Roof Configurations

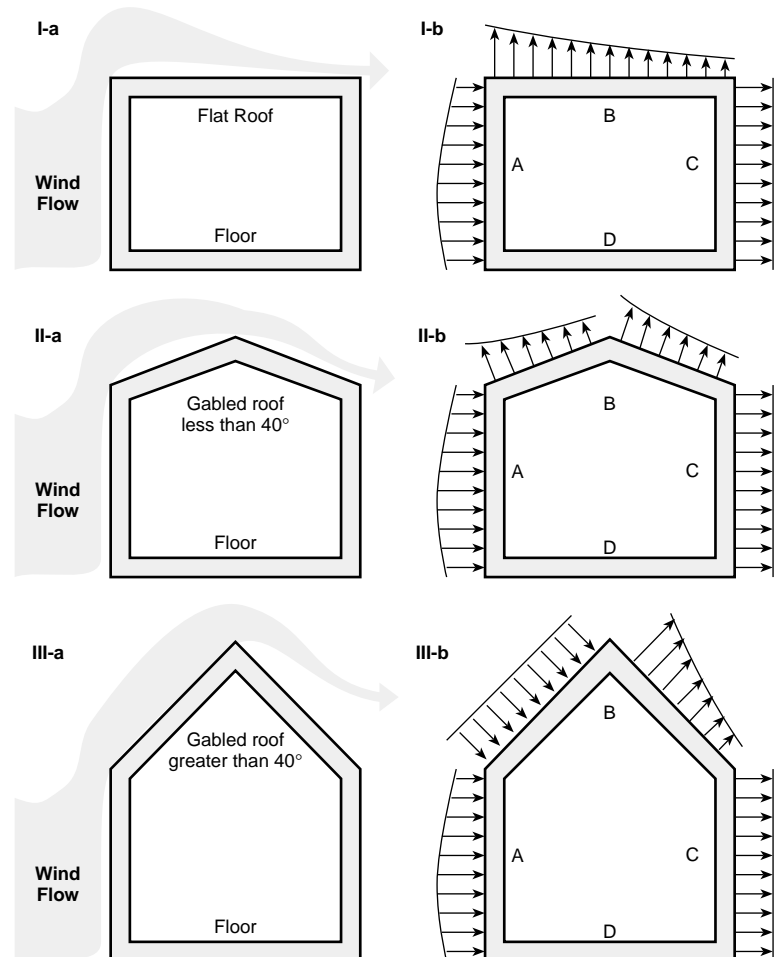
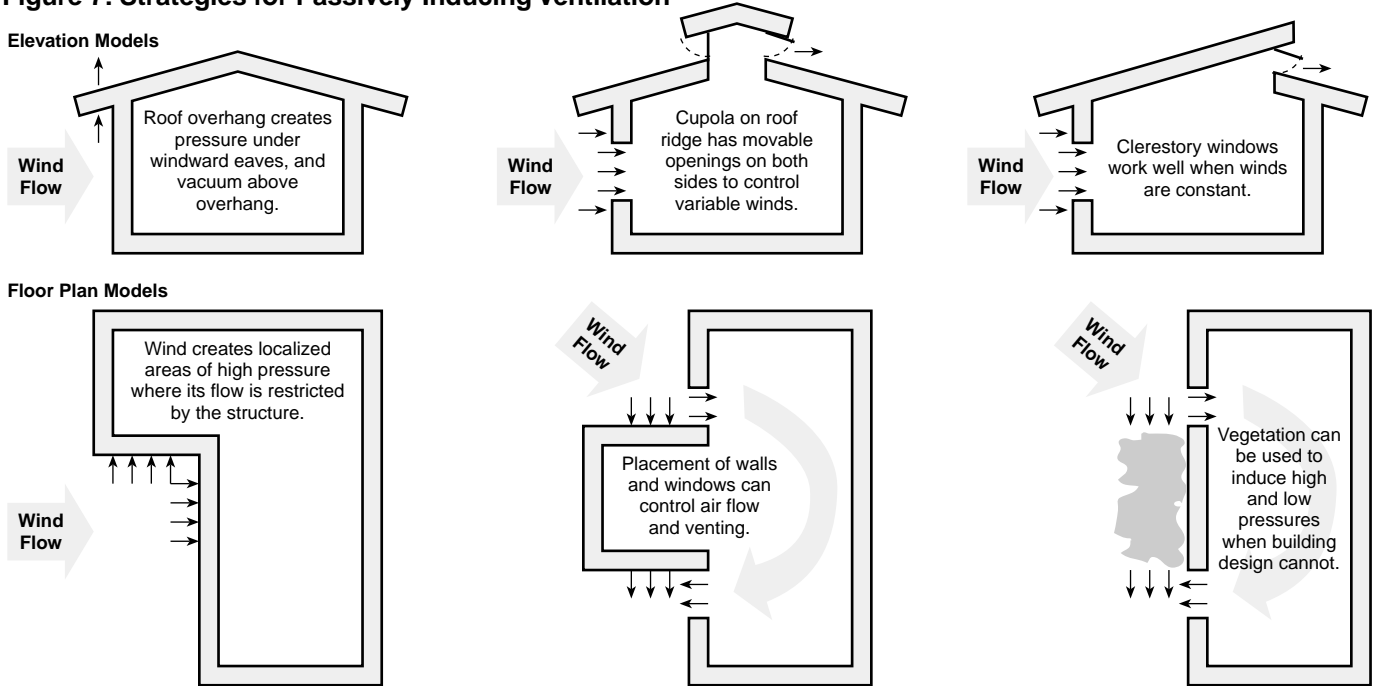

Figure 7: Strategies for Passively Inducing Ventilation



Direct Action on Building

Figure 7 illustrates some specific building treatments that are effective in fostering passive building ventilation. The important concept here is that even under moderate wind loads, there are pressure differentials on the outside walls and roof of the structure. If the designer takes advantage of these, it is

Vent windows placed high on the downwind wall allow negative pressure to extract hot air from inside.



possible to induce significant forced ventilation circulation through a structure. Under the right conditions, this ventilation will equal or exceed what you could obtain with an electric fan.

Conclusion

In *Passive Cooling Part 1—Basic Principles*, I described the three basic mechanisms of heat transfer. I also related the transfer of heat to the sensation of comfort that people seek.

In *Passive Cooling Part 2—Applied Construction*, I have tried to relate the basic information in Part I to the world of wood, concrete, and glass. Here, to a limited degree, I have shown specific building techniques for thwarting the penetration of heat into a living environment. I've covered the principles and pitfalls of using natural forces to create that comfort envelope we seek in order to keep the effects of excessive heat at bay.

I have also tried to list other, more extensive sources of information on the subject of passive cooling, for the enthusiastic reader. I hope this has been of some help to people trying to live comfortably in the humid tropics. It can be done.

Access

Cliff Mossberg, PO Box 16, Kasilof, AK 99610
attara@gci.net

Resources for further study:

Architecture For the Poor, 1973, and *Natural Energy and Vernacular Architecture, Principles and Examples with Reference to Hot Arid Climates*, 1986, by Hassan

Fathy, both published by The University of Chicago Press, Chicago. These books can be hard to find. I was able to locate them through my regional inter-library loan program.

Building for the Caribbean Basin and Latin America; Energy-Efficient Building Strategies for Hot, Humid Climates, Kenneth Sheinkopf, 1989, Solar Energy Research and Education Foundation, 4733 Bethesda Ave., #608, Bethesda, MD 20814 • 301-951-3231 Fax: 301-654-7832 • plowenth@seia.org www.seia.org

Radiant Barriers: A Question and Answer Primer, by Ingrid Melody • Florida Solar Energy Center www.fsec.ucf.edu/Pubs/EnergyNotes/En-15.htm

Low Energy Cooling; A Guide to the Practical Application of Passive Cooling and Cooling Energy Conservation Measures, Donald W. Abrams, Van Nostrand Reinhold Company, New York, 1986 Apparently no longer in print, but check with used bookstores and inter-library loan.

Passive Cooling, 1989, edited by Jeffrey Cook, US\$55 from The MIT Press, 5 Cambridge Center, Cambridge, MA 02142 • 800-356-0343 or 617-625-8569 Fax: 617-625-6660 • mitpress-orders@mit.edu http://mitpress.mit.edu



Be Part of the Solution

Murdoch University offers qualifications in the technical, economic and policy aspects of renewable energy.



- Bachelor of Science (Energy Studies)
- Bachelor of Renewable Energy Engineering (on-campus only)
- Postgraduate Certificate (Energy Studies)
- Postgraduate Diploma (Energy Studies or Energy & Environment)
- Master of Science (Renewable Energy)
- Research Degrees
- Professional Development Courses

These qualifications are available entirely via the internet enabling part-time or full-time study anywhere in the world!

For information contact: Professor Philip Jennings, Murdoch University, Perth, Western Australia 6150 Ph +61 (0)8 9360 2433 Fax +61 (0)8 9360 6183 Email jennings@acre.murdoch.edu.au

<http://www.acre.murdoch.edu.au/>

These 1000 watt Stream Engine units were used for one week at the "Festival for Eno". We donated the power and the work for the protection of this river. We now have these units on sale for \$899.00 each Call today Solar Village 800-367-9530

Solar Village
Institute Inc.
PO Box 14, Saxapahaw, NC 27340
Or visit the website
www.solarvillage.com
tel. 336-376-9530 Fax 336-376-1809

Stream Engine
Things that Work!

AWP36 Wind Generator

**Rugged, simple construction.
Gravity furling system.
Only 3 moving parts.**

- Large rotor optimized for low wind speeds
- Simple rugged design, only 3 moving parts
- Low maintenance
- 1,000 watts @ 25 mph

For only \$1969



Available in:
12, 24, 48, & 220 V

Abundant Renewable Energy

22700 NE Mountain Top Rd.
Newberg, OR 97132
503-538-8292 • rwpreus@yahoo.com
Dealer inquiries welcome