

## *The DuPlex Booster*

### **The DuPlex Booster**

Bill Williams of the USA has developed and tested an easily-built booster, based on Bob Boyce's seven-cell design of some years ago. As Bill's booster is somewhat advanced in design, a somewhat simplified version is presented first, followed by the full design.

A really big advantage of this design is that no container is used, the plate material is thin enough to be cut by hand and no high-precision construction work is needed. The basic cell looks like this:



There are two strong A36 steel alloy end plates which act as clamps to lock the remaining plates in position as well as acting as electrodes. A ring of eight cadmium plated steel bolts are used to lock the unit together and these bolts also keep in position, a set of circular plates and O-ring gaskets (McMaster-Carr, Part Number - 9557K338, made of EPDM - Ethylene Propylene, Outer diameter 6.4" or 162 mm) as shown here:

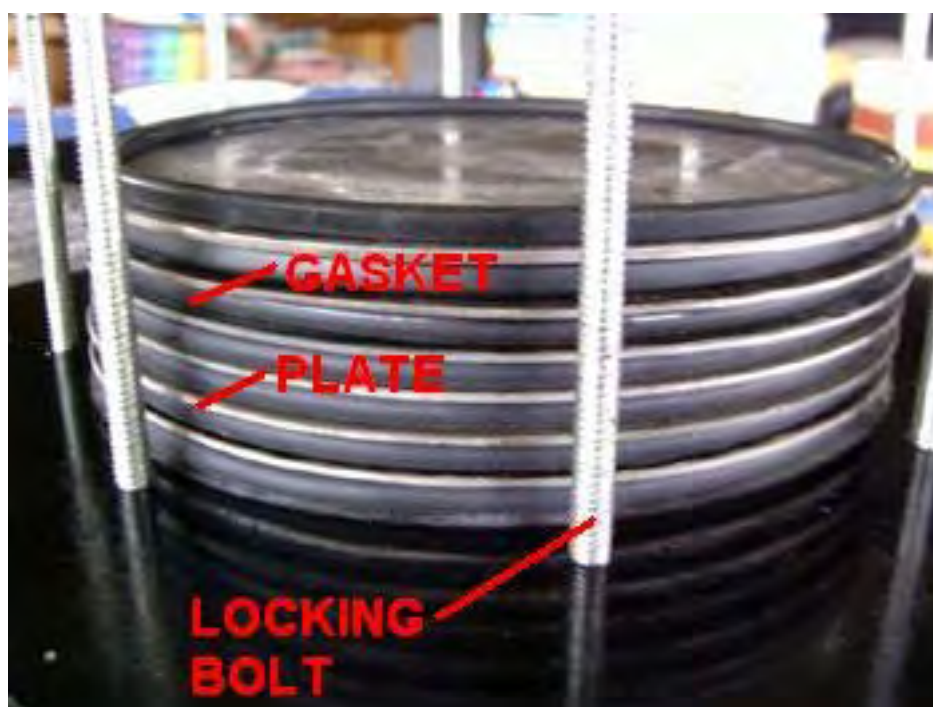

To make sure that the locking bolts do not short-circuit the plates, they are fitted with 3/8" (9 mm) outer diameter / 1/4" (6 mm) inner diameter rubber fuel-hose material.

The end plates receive careful preparation. They are first cleaned of mill-scale by being submerged in hydrochloric acid and connected to a DC power supply. A scrap piece of stainless steel is connected to the DC minus and the plate to the DC plus. This is, of course, done in a well-ventilated area and while wearing safety clothing, gloves and goggles. The cleaning process takes only five minutes or so, and then the plate is rinsed off with clean water. This process produces a good clean plate surface. The pipe fittings which Bill uses are to the US "National Pipe Thread" ("NPT") thread pitch but your local thread pitch is just as suitable, especially since Bill opts to weld the fitting to the outside of the plate as shown here:

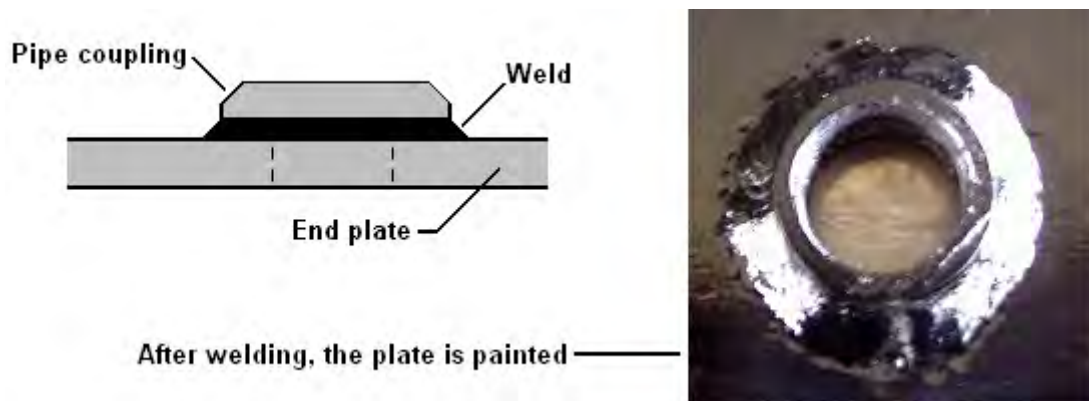

The recommended **end-plate pipe fittings** are:

Bottom fittings: 90° male 1/2" NPT to 1/2" male tubing (2 required)

Top fittings: 1/2" NPT male T-piece to 3/8" male tubing, 90° (2 required)

The **Tank/Bubbler pipe fittings** are:

Bottom, outer fittings: 1/2" NPT male T-piece, to 3/8" male tubing (2 required)

Bottom, centre fitting: 1/2" NPT male to 1/2" male tubing (1 required)

Top, centre fitting (gas outlet): 1/2" NPT to 3/8" male 90° (1 required)

Top, outer fitting (manual refill): 1/2" NPT plug (1 required)

After the pipe fittings have been welded in place, the parts of the plates which can be seen from the outside are given a protective coat of paint. This paint avoids the area around both ends of one of the clamping bolts as the electrical connection is made to that bolt and so it has to be in very good electrical connection with both of the end plates. The electrical arrangement has the two outside plates connected together and the centre plate used as the other electrical contact. This produces two separate 6-cell boosters, back to back. The simplified version is arranged like this:

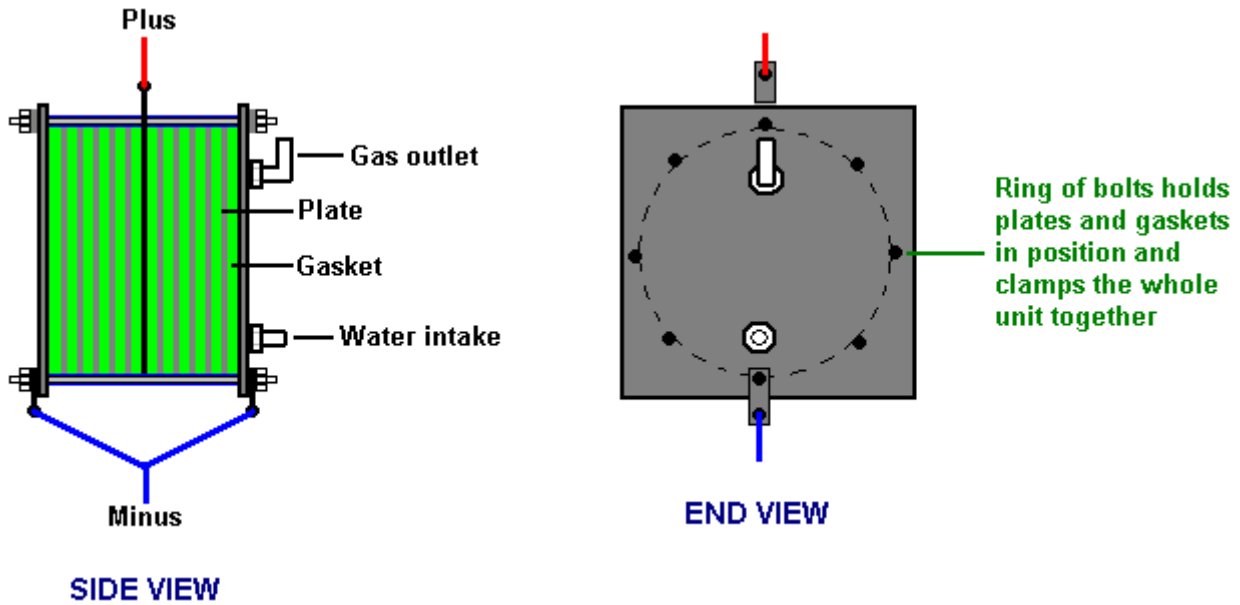

In both arrangements, there are five circular plates on each side, which, with the end plates and the centre plate, form two separate boosters of six cells each (which is why it is called the "DuPlex" booster). The central plates are constructed from 0.047" (1.2 mm) 316L-grade stainless steel sheet. This thickness of sheet can be hand-cut using good quality Tin Snips. The ten "floaters" plates look like this:

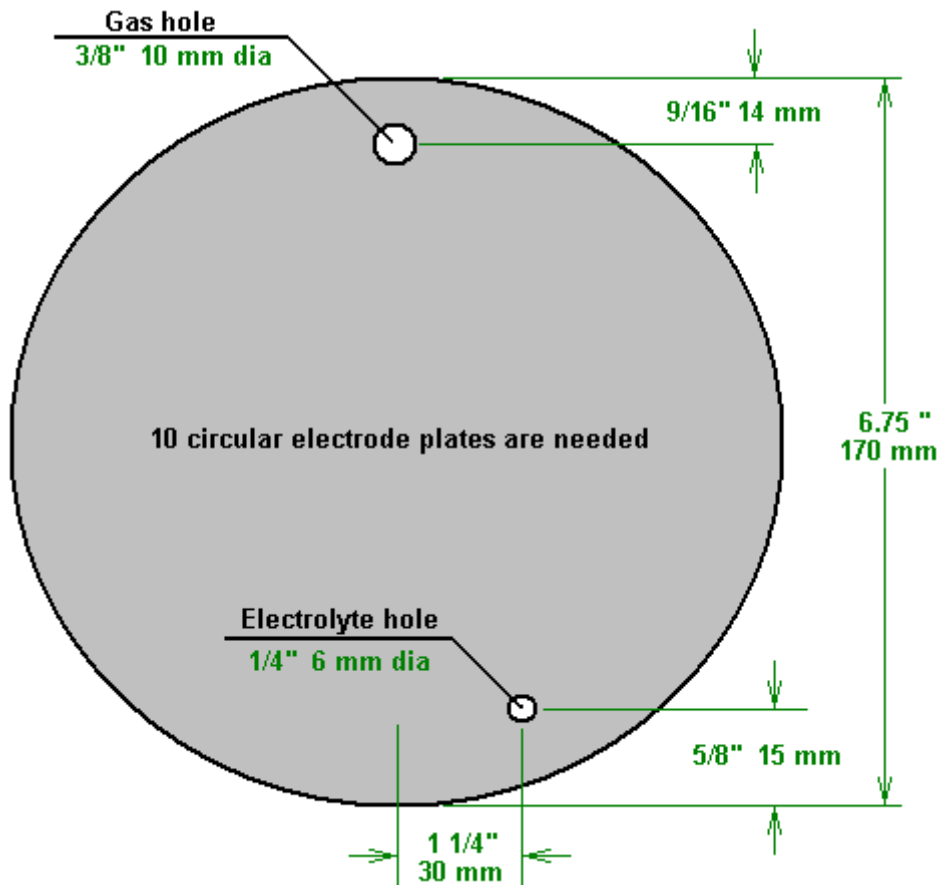

Every second one of these plates is turned around so as to stagger the bottom holes and give a longer electrical path for the current flow through the electrolyte. In the simple version, just one of the end plates is drilled to accept the gas output pipe fitting and the water inlet pipe fitting as shown above. In this version, the central plate which is connected to the battery plus, also has holes drilled in it and so looks like this:

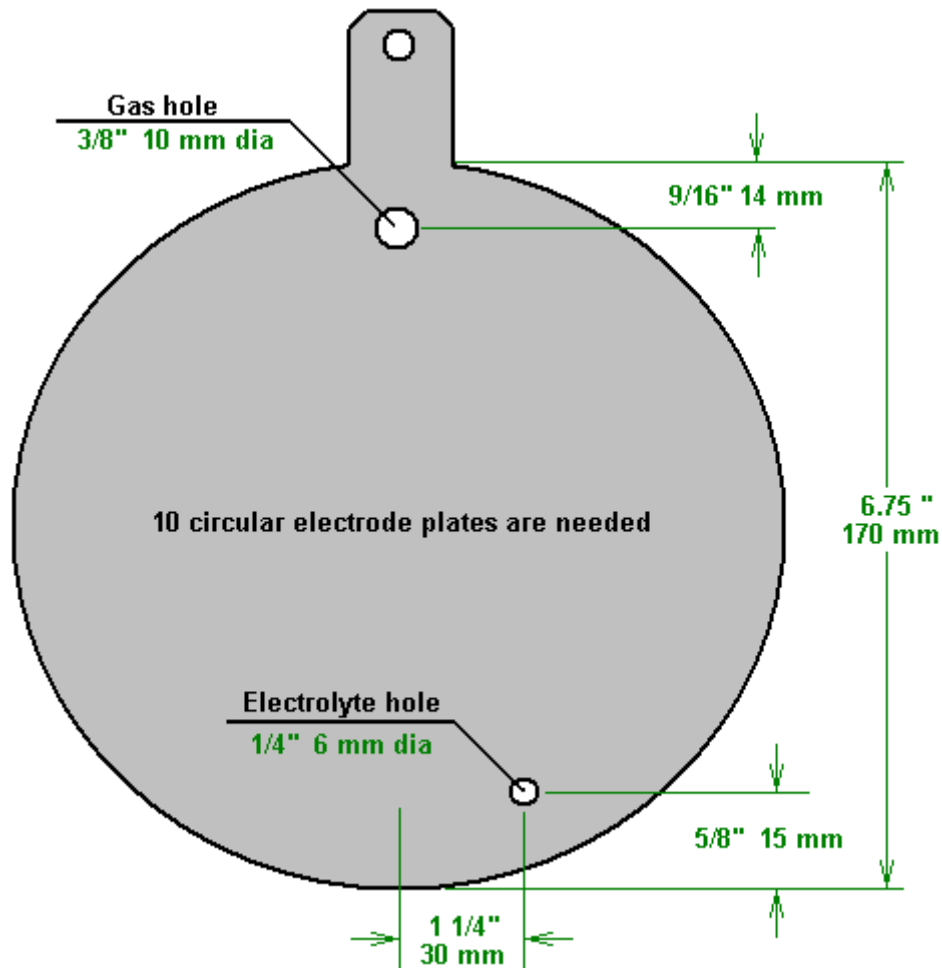

This allows a single-ended arrangement like this:

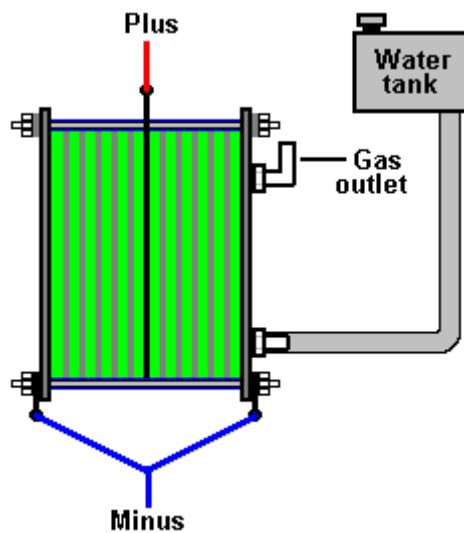

However, Bill prefers a more advanced double-ended arrangement as that allows him to select one or both of the gas outlets, depending on road conditions. When the engine is idling or under very light loading, Bill switches to have just one gas outlet, but when full speed engine use is needed, he operates the booster with both gas outlets connected. The water feed is then like this:

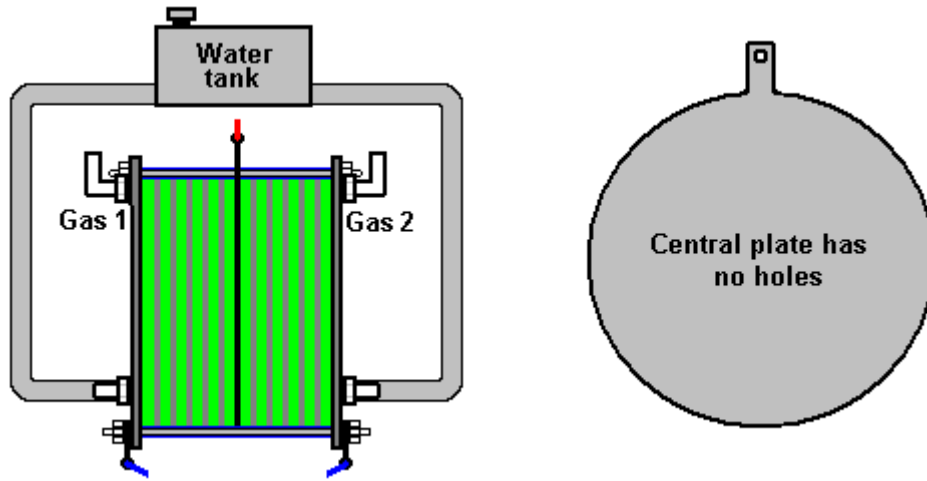

As a final step, Bill uses the water in the water tank as a bubbler as well as the water supply:

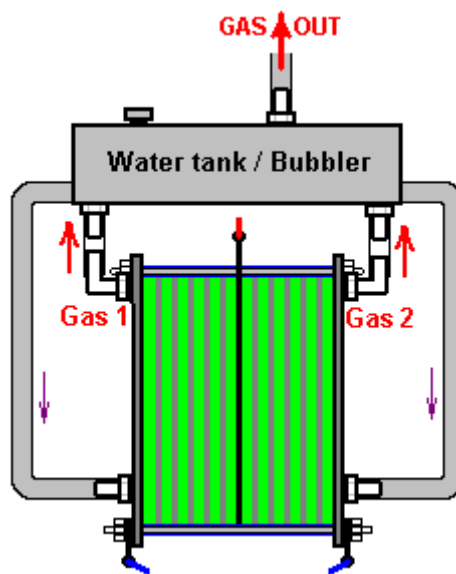

This is an unusual arrangement as the whole of the booster is deliberately flooded. Gas bubbles produced on the plates rise up and collect at the top of the plates until they escape through the gas holes and pipe fittings, passing upwards through the water tank which then acts as a bubbler. It is very important to remember that while only pure water is added to the water tank, because of its connection with the electrolyte in the booster, the tank also contains electrolyte and not just water. This means that you need to be careful with it. Also, if you open the tank to add water, remember that it will contain hydroxy gas, so don't allow any flame or spark near it until the gas has escaped upwards and dispersed. As the water tank contains electrolyte, it is essential to have at least one plain-water bubbler between this booster system and the engine, so that any electrolyte fumes are washed out of the gas before it reaches the engine.

The end plates are made from 1/4" (6 mm) stainless steel and the pipe fittings are nickel-plated brass elbows, Part Number B-404-90-EN from [www.hofmannfluidpower.com](http://www.hofmannfluidpower.com) which takes a 1/2" (12 mm) inner diameter plastic pipe. The four holes in the end plates have a weld-on coupler fitting welded above them. These can be the Part Number 12555K73 from McMaster-Carr <http://www.mcmaster.com/> :



The advantage of making the pipe connections this way is that additional fittings which screw into these coupler fittings can be removed quite easily and they have their full threaded length gripped in spite of the very restricted

gap behind the end plate and the relative thinness of the end plate itself. The four fittings which screw into these couplers look like this:



This booster produces 3 lpm of hydroxy gas for an input current of just 15 amps. The booster temperature does not rise to any excessive level. Here is a photograph of the prototype which has undergone very extensive testing:



The final step is to maintain the electrolyte level in the header tank/bubbler. This liquid level is held within quite tight limits in order that the electrolyte concentration can be kept to the desired concentration. The electrolyte used is the optimum concentration for efficient electrolysis. This is 20% by weight of sodium hydroxide (NaOH) or 28% by weight of potassium hydroxide (KOH). The potassium is 20% more electrically efficient for electrolysis.

A 20% "by weight" concentration of NaOH has 200 grams of NaOH added to 800 cc of distilled water. A 28% "by weight" concentration of KOH has 280 grams of KOH added to 720 cc of distilled water. Please pay very careful attention to the safety precautions needed for safely mixing electrolyte solutions. These precautions are shown elsewhere in this document and it is very important to follow them carefully. The water supply arrangement is then like this:

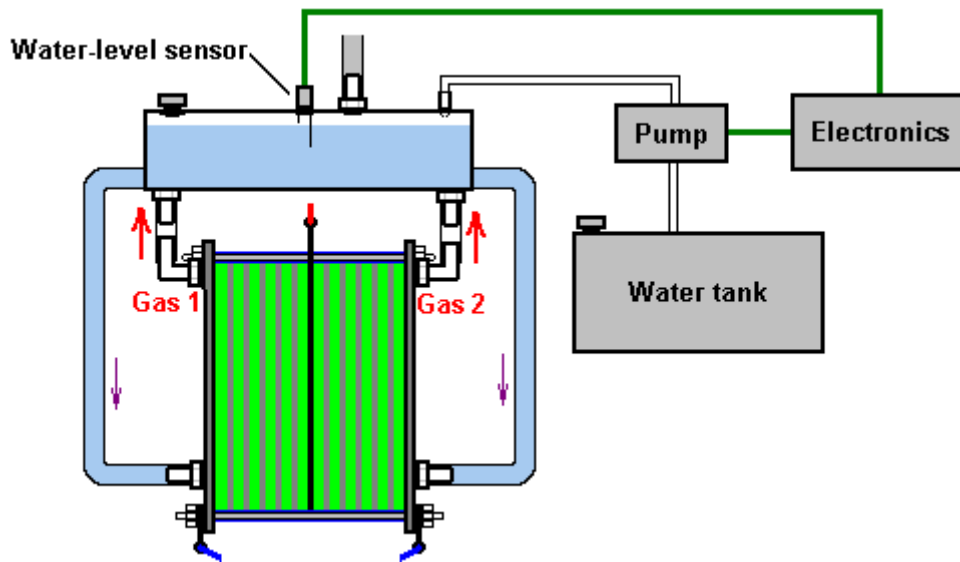

The additional fitting on the top tank for the water inlet from the water pump is a McMaster-Carr 1/4" fitting for a 3/8" pipe, and that is Part Number 1145K52.

**Caution: This booster is not a toy. If you make and use one of these, you do so entirely at your own risk. Neither the designer of the booster, the author of this document or the provider of the internet display are in any way liable should you suffer any loss or damage through your own actions. While it is believed to be entirely safe to make and use a booster of this design, provided that the safety instructions shown below are followed, it is stressed that the responsibility is yours and yours alone.**

A booster should not be considered as an isolated device. You need to remember that both electrical and gas safety devices are an essential part of any booster installation. The electrical safety devices are a circuit-breaker (as used by any electrician when wiring a house) to protect against accidental short-circuits, and a relay to make sure that the booster does not operate when the engine is not running:

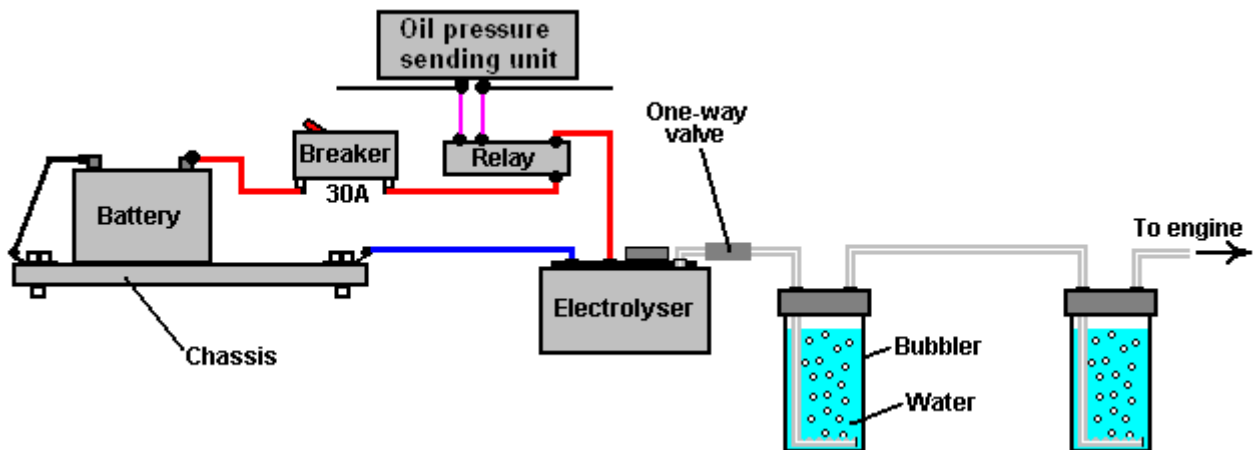

The bubblers are there to wash every last trace of electrolyte fumes out of the hydroxy gas being fed to the engine, and to protect against a flash-back caused by the engine misfiring due to a valve sticking. There is more information on these things in chapter 10 on the <http://www.free-energy-info.com> website.

Patrick Kelly  
[engpjk@gmail.com](mailto:engpjk@gmail.com)  
<http://www.free-energy-info.com>  
<http://www.free-energy-devices.com>